



STUDENT MANUAL MODULE 2B SHORING CONSTRUCTION

MODULE PURPOSE

The purpose of this unit is to explain **HOW** we build shoring in the **FEMA Response System** so that the process is always consistent and efficient.

There are many other types and methods to construct shoring, however, it is important that all rescue personnel within this program learn to efficiently construct these systems.

They have been engineered as well braced, reliable systems that can be rapidly constructed in emergency conditions.

TERMINAL OBJECTIVES

- The student shall learn how to maintain the integrity of all structurally unstable elements
- The student shall learn how to properly transmit or redirect the collapse loads to stable ground or other stable structural elements, capable of handling the additional loads

ENABLING OBJECTIVES

At the conclusion of this module the student should:

- Have a basic understanding of how to conduct a proper size-up
- Be able to identify locations for proper shoring placement
- Understand the shoring team concept and identify the positions and purpose
- Understand the different types of FEMA shoring components and equipment

National Urban Search & Rescue Response System
Structural Collapse Technician Training



Terminal Objectives

- The Student shall learn how to maintain the integrity of all structurally unstable elements
- The Student shall learn how to properly transmit or redirect the collapse loads to stable ground or other suitable structural elements capable of handling the additional loads

SCT2b Slide 2

National Urban Search & Rescue Response System
Structural Collapse Technician Training



Enabling Objectives

- Have a basic understanding of how to conduct a proper shoring size-up
- Be able to identify locations for proper shoring placement
- Understand the shoring team concept and identify positions & purpose
- Understand the different types of shoring components and equipment

SCT2b Slide 3



MITIGATION BASICS

- **Avoid It** - barrier tape around a hazardous area preventing access.
- **Remove It** - pull down a cracked and leaning brick chimney.
- **Shore It** - constructing shoring and/or bracing systems.
- **Monitor it** – setup Monitoring with a warning system and pre-planned escape/evacuation plan.

SHORING SIZE-UP

- The Shoring Size-Up provides a survey of structural damage and potential victim locations in buildings identified during the initial building triage and Structure/Hazards Evaluation process.
 - Identify structural hazards, damage and potential victim locations.
 - Determine best method to mitigate the structural hazards and damage. Avoid, remove, shore, or monitor.
 - Determine the type and placement of shoring systems in relation to structural hazards, damage and potential victim location.
- The shoring size-up should be performed by at least a Structural Specialist, Rescue Team Manager and/or Rescue Squad Officer.
- The shoring size-up must be extensive, accurate and continue throughout the rescue operation.

National Urban Search & Rescue Response System
Structural Collapse Technician Training



Hazard Mitigation

- **AVOID IT** - prevent access to the hazardous area
- **REMOVE IT** - pull down cracked and leaning chimney
- **SHORE IT** - construct a shoring system
- **MONITOR IT** - set up warning system & escape plan

SCT2b Slide 4

National Urban Search & Rescue Response System
Structural Collapse Technician Training



Shoring Size-up

- **Identify structural hazards, damage and potential victim locations**
- **Determine best method to mitigate the hazard and damage**
- **Determine the type & placement of shoring systems in relation to structural hazards and potential victim location**

SCT2b Slide 9

National Urban Search & Rescue Response System
Structural Collapse Technician Training



Size-up Cont.

- **Performed by at least a structural specialist, rescue team manager and / or a rescue squad officer**
- **It must be extensive, accurate and continue throughout the rescue operation**

SCT2b Slide 10



USE OF GUSSET PLATES IN INTERIOR SHORING

- As discussed in Module 2a, the best shoring should have positive connections.
- In Disasters where any type of vibration or shock loading is possible, it is very important to make the connections strong enough to resist repeated impacts.
 - To do this it is necessary to provide a Half-Gusset or 2x6 bracing connection on each side at the bottom of each post in order to confine the wedges and prevent the sole from possible rollover.
 - At the tops of these same posts, it is adequate to provide a one sided connection if the header is no deeper than its width (4x4 & 6x6) . That is, on end posts the 2x6 bracing connection is adequate. For interior posts, one may use a half-gusset or 2x cleat on one side only
 - The 2x6 and half-gussets are nailed with standard nailing that will be discussed later in this section.
- There may be some incidents where interior shoring is needed, but the conditions are such that well connected shores are not necessary. This will always be a judgment call, and one may wish to discuss this with the Structures Specialist.
 - The type of conditions that might allow the use of these minimally connected shores are shown in the adjacent slide.
 - Loads should be light, the rescue should be very short term (in the range of one hour), and the overall structure should be very stable
 - Even in these cases, a minimum of two toenails should be used on two sides of each post

SHORING SIZE-UP CONSIDERATIONS

Victims

- How many victims are trapped and where are they located?
- Is the information coming from reliable sources and can it be confirmed?

National Urban Search & Rescue Response System
Structural Collapse Technician Training



Use of Gusset Plates in Vertical Shoring

- In most cases, especially following earthquakes, gusset plates are needed on both sides of posts at the base of shores to keep wedges in place.
- When headers are deeper than 4", gussets are needed both sides to prevent header roll-over
- Gussets may be placed on one side only for 4x4 and 6x6 headers at the inner posts.
 - At the end posts, the 2x6 diagonal on one side replaces the need for a gusset plate

SCT2b Slide 11

National Urban Search & Rescue Response System
Structural Collapse Technician Training



Size-up Considerations

- VICTIMS
- SIX SIDED APPROACH
- STRUCTURAL ELEMENTS
- AGE & CONDITON OF STRUCTURE
- COLLAPSE WARNING SIGNS

SCT2b Slide 12



SHORING SIZE-UP CONSIDERATIONS (continued)

Six-sided Approach

- Survey all four sides, the top and the bottom of the entire structure paying particular attention to the collapse area.
- The top survey is extremely important because loose or hanging debris, structural elements and other overhead hazards must be identified and addressed.
- Gravity being constant, will continually try to pull the remains of the structure and its contents to the ground.
- Surveying the bottom is equally important because shifted loads created by the collapse must be transferred to other stable structural members or back to stable ground.

Structural Elements

- Walls out of plumb determine building stability immediately on arrival.
- Bearing walls are the most important structural elements in an unframed building and failure of any part of these walls can cause extensive damage and further collapse.
- Identification and assessment of all beams, columns, arches, joists and other structural supporting elements under the main debris pile or the victim's location should be among the top priorities of the shoring size-up.
 - All severely stressed, broken, missing, bowed or cracked supporting elements which could affect the rescue operation must be shored up before any personnel are committed to work in the area.
 - The building elements they supported must also be examined and re-supported.

Age and Condition of the Structure

- The shrinkage of structural elements over time results in a loss of strength and the loosening of important hangers and connecting supports which may require more shoring.
- Supporting elements of a well-maintained building may be utilized to help support and transfer the collapse load throughout the structure. However, if the building's condition was in a state of disrepair or suspect prior to the collapse, do not assume any structural support exists without a thorough inspection.

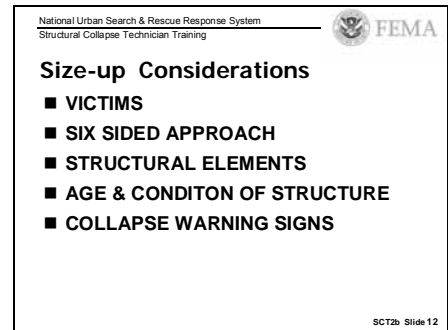



SHORING SIZE-UP CONSIDERATIONS (continued)

Collapse Warning Signs

- Continual surveillance of the structure from several vantage points must be maintained from the time of arrival to the time the last rescue personnel have exited the building.
- Surveyor total stations/theodolite are excellent tools for detecting any wall and floor movement.
- Pay particular attention to signs of a possible secondary collapse, including shifting debris, airborne dust, sliding plaster & structure sounds like creaking, moaning & groaning.

SHORING PLACEMENT

Two Main Objectives

- Maintain the integrity of all structurally unstable elements
- Properly transmit or redirect the collapse loads to stable ground or other suitable structural elements capable of handling the additional loads.

Shoring Placement Considerations – Multi Story Structures

- From the previous Manual Section – when shoring a single damaged floor in multi-story, sound, existing bldg the following procedure may be used:
 - For Wood-frame, one undamaged floor can support one damaged floor
 - For Steel-frame, it takes two undamaged floors to support one damaged floor
 - For Reinforced Concrete, it takes three undamaged floors to support one damaged floor
 - For Precast Concrete, the shoring should extend to the slab that is supported by the ground
 - This assumes that the structure is a reasonable structure, and not heavily loaded with furniture, storage or debris.
 - This does not apply to structures that are under construction, or subject to cascading/progressive collapse
 - This also does not apply to structures that have collapsed suddenly, without any apparent cause
- Shoring primary structural supporting elements such as walls, girders, columns & arches will more effectively utilize shoring materials and existing construction features of the building.

National Urban Search & Rescue Response System
Structural Collapse Technician Training

Size-up Considerations

- VICTIMS
- SIX SIDED APPROACH
- STRUCTURAL ELEMENTS
- AGE & CONDITON OF STRUCTURE
- COLLAPSE WARNING SIGNS

SCT2b Slide 12

National Urban Search & Rescue Response System
Structural Collapse Technician Training

Shore Placement – Multi Story

- Review from previous – Existing Bldgs
 - Wood Bldg, one undamaged floor can support one damaged floor
 - Steel Bldg, 2 undamaged for 1 damaged
 - Reinforced Concrete, 3 for 1
 - Precast Conc, Start at ground
- Assumptions
 - “Normal” furniture loading, no heavy stuff
 - Not for buildings under construction – see StS
 - Not for any bldgs that collapse unexpectedly
 - ◆ w/o Quake, Blast, etc – may have flaws

SCT2b Slide 13

National Urban Search & Rescue Response System
Structural Collapse Technician Training

Shoring Placement

- Where to place Shoring
 - Support unstable Structural Elements
 - Under Debris Pile
 - Under Victim Location

SCT2b Slide 14

National Urban Search & Rescue Response System
Structural Collapse Technician Training

Shoring Placement - cont

- Sequence for multi-story Shoring – Where do you start?
 - Start directly under lowest “Damaged” or “Overloaded” Floor in order to share the load
 - Keep shoring in all stories vertically aligned
- Other Strategies
 - Shore from Outside - In
 - Shore for Team access & egress
 - Phased approach – Class 1, 2 & 3
 - ◆ Spot shore - Class 1 T, but Dbl T is better
 - ◆ 2 Dimensional - Class 2 2 or more Post Vertical
 - ◆ 3 Dimensional - Class 3 Laced Post, Sloped Floor

SCT2b Slide 17



Shoring Placement Considerations (continued)

- The area beneath the main debris pile must be examined and shored to provide additional support to the existing, loaded structural elements, before any personnel can be committed to rescue operations on top of the debris pile.
- Also, the area directly underneath the victim(s) and rescue forces must be shored up before significant debris removal operations are attempted. Shores may need to be re-tightened continually as debris are removed.
- Shoring system(s) must be located where they will not interfere with the removal of the victim(s).
- All loads transferred to earth (or other structural element capable of handling the additional load) require the shoring systems(s) to be located where they will bear on each other.
 - The best strategy for multi-story shoring is to start directly under the damaged floor, and work down
- Access into the building may require shoring to be started from the point of entry to where the victim is located. Sections of shoring may have to be built to create safe zones & safe passageways.
- In the most dangerous conditions, it is best to use a phased approach, where Class 1, spot shores (Dbl T is preferred) are placed first to reduce risk.
 - These shores may be followed by Class 2, two dimensional, and then Class 3, three dimensional shores, as risk is further reduced

THE SHORING TEAM

To conduct shoring operations safely and efficiently two separate teams are formed.

- The **Shore Assembly Team** - Performs the actual shoring size-up and construction of the shores.
- The **Cutting Team** -Establishes the equipment area and cuts the shoring lumber.
- For most cases, a single Rescue Squad can normally fill the six individual shoring team positions
- Larger or more complex shoring operations may require two complete Rescue Squads, with one squad assigned to the Shore Assembly Team and the other assigned to the Cutting Team.

National Urban Search & Rescue Response System
Structural Collapse Technician Training

Shoring Placement - cont

- Sequence for multi-story Shoring – Where do you start?
 - Start directly under lowest "Damaged" or "Overloaded" Floor in order to share the load
 - Keep shoring in all stories vertically aligned
- Other Strategies
 - Shore from Outside - In
 - Shore for Team access & egress
 - Phased approach – Class 1, 2 & 3
 - ◆ Spot shore - Class 1 T, but Dbl T is better
 - ◆ 2 Dimensional - Class 2 2 or more Post Vertical
 - ◆ 3 Dimensional - Class 3 Laced Post, Sloped Floor

SCT2b Slide 17

National Urban Search & Rescue Response System
Structural Collapse Technician Training

Shore at Missing Structural Supports

- Walls
- Beams
- Columns
- Girders
- Arches

SCT2b Slide 19

National Urban Search & Rescue Response System
Structural Collapse Technician Training

The Shoring Squad

SHORING TEAM	CUTTING TEAM
SHORING OIC	LAYOUT FF
MEASURING FF	CUTTING FF
SHORING FF	TOOL & EQUIP FF

SCT2b Slide 20



THE SHORE ASSEMBLY TEAM – MINIMUM SIZE

- The **Shoring Officer** (Rescue Squad Officer) in charge of the operation and works with the structural specialist to determine where to place and erect the shores.
- The **Measuring** performs all the measuring required in the erection of the shoring and relays all measurements and lumber sizes to the layout of the cutting team.
- The **Shoring Fire Fighter** clears away debris and obstructions that could interfere with constructing the shore, assists the measure as needed and erects the shores.

THE CUTTING TEAM – MINIMUM SIZE

The initial responsibility of the cutting team is to secure an area as close as possible to the collapse operation so as to minimize the number of personnel needed to relay the materials to the shore assembly team.

The assistance of several other personnel may be required to help expedite the movement of lumber and tools to the collapse area.

- The **Layout** in charge of setting up the cutting station and readying the materials to be cut.
 - Performs all measuring and layout of angles and should be in direct contact with the shore assembly team measurer via portable radio to eliminate problems in mis-communicating measurements of lengths to be cut.
- The **Cutter** cuts the shoring material.
- **Tools and Equipment** directs the movement of tools and equipment to be placed where they are requested, anticipates logistical needs of the shoring team and keeps an inventory checklist/log sheet for easier retrieval of tools and equipment at the conclusion of rescue operations.

National Urban Search & Rescue Response System
Structural Collapse Technician Training



The Shoring Squad

SHORING TEAM	CUTTING TEAM
SHORING OIC	LAYOUT FF
MEASURING FF	CUTTING FF
SHORING FF	TOOL & EQUIP FF

SCT2b Slide 20



THE SHORE ASSEMBLY TEAM – FULL SQUAD

- The Shoring Officer (Rescue Squad Officer)
- The Measurer
- Shoring FF (these two work together assembling and erecting shores in place)
- Safety
- Runner ensures tools, equipment, & shoring materials are moved from the shoring operation access point to the shoring site and assists in the erection of shores.

THE CUTTING TEAM – FULL SQUAD

(1 Cutting Tm Squad provides for 3 or 4 Shoring Squads)

- The Cutting Team Officer (Rescue Squad Officer)
- The Layout
- The Feeder moves and feeds measured and marked shoring material from the Layout to the Cutter and helps secure it when being cut.
- The Cutter
- Tool and Equipment
- Runner - ensures tools, equipment and shoring materials are moved from the cutting area to the shoring operation primary access point.

SHORING TERMINOLOGY

See the three adjacent slides for Standard FEMA Shoring Terminology

- Headers, Sole Plate, Wall Plate, Post, and Raker are the primary members that carry or transfer the loads
- Diagonal Bracing may be 2x6 or 2x4 depending on shore. (2-2x4 may substitute for 2x6 as 2nd choice)
- Mid point braces for vertical shores = 1x6, (3/4" x 6" plywood is 2nd choice substitute)
- Mid-point brace for Rakers = 2-2x6
- Cleats may be any of the following:
 - Raker Cleat, 45 deg = 2x4x24" : 60 deg = 2x4x30"
 - Window and Door Cleats = 2x4x14" min at wedges
 - Other Cleats = 2x4x18" min.
- Plywood Gussets are as follows: (3/4" is standard)
 - Full gusset at rakers = 12" sq
 - Half gussets at vertical & horiz. shores = 6"x12"
 - Double gussets at Double Tees = 12" x 24"
 - Triangular gussets at Window & Door Shores
- Wedges & shims are from diagonally cut 2x4 or 4x4.

National Urban Search & Rescue Response System Structural Collapse Technician Training	
Shore Assembly Team	Cutting Team
<u>SHORING OIC</u>	<u>CUTTING TEAM OIC</u>
MEASURING FF	LAYOUT FF
SHORING FF	FEEDER
SHORING FF	CUTTING FF
SAFETY FF	TOOL& EQ FF
RUNNER	RUNNER

SCT2b Slide 21

National Urban Search & Rescue Response System Structural Collapse Technician Training	
Shoring Terminology	
■ Header	Collects load at roof and floor
■ Sole Plate	Transmits load to floor or ground
■ Wall Plate	Collects load from wall/vert. surface
■ Post	Transmits load from header to sole
■ Raker	Transmits load from wall plate to sole
■ Raker Cleat	24" to 30", 2x used as connection piece to resist sliding

SCT2b Slide 22

National Urban Search & Rescue Response System Structural Collapse Technician Training	
Shoring Terminology (cont)	
■ Gussets	12" Sq. x 3/4" Ply conn. for rakers
■ Half Gusset	6" x 12" x 3/4" Ply conn. for vert shores (Use 2x4x18" cleat if have no Ply)
■ Dbl Gusset	12" x 24" Gusset used for Dbl T
■ Mid Pt Brace	Lumber used to connect rakers or posts at mid point for bracing
■ Diagonal Bracing	2x lumber placed on diagonal in X or V to keep shoring from racking

SCT2b Slide 23

National Urban Search & Rescue Response System Structural Collapse Technician Training	
Shoring Terminology (cont)	
■ Window & Door Cleats	2 x 4 x 14" minimum – up to 18"
■ Wedges	2x or 4x lumber cut, diagonally into 2 pieces to allow for adjustments in height/length (2x are more stable)
■ Shims	Any piece of lumber, wedge shaped or flat that is used to fill-in void spaces

SCT2b Slide 24



THE "T" SPOT SHORE

- The main purpose of the "T" shore is to initially stabilize damaged floors, ceilings or roofs, so that the more substantial shoring can be constructed at less risk.
- The T Shore is basically unstable.
 - That is if the supported load is not centered directly over the Shore, it will tend to tip over.
 - The header beam is deliberately kept short so as to minimize to effect of tipping.
- The size of lumber most commonly used in the T shore is 4 X 4 douglas fir. The estimated weight of the floor and its contents will help to determine the number of shores that will be required.
- Structural Components of the T shore
 - The **Sole Plate** provides a foundation for the shoring system by supporting the weight being transferred from above/distributes it over a wider area.
 - The **Header** collects the weight from above and spreads it throughout the shoring system.
 - The **Posts** supports the weight being collected by the header or spreader beam and transfers it to the sole plate where it is distributed.
 - The **sole plate, header and posts** should be the same width for a more secure attachment.
 - **Full-Gusset Plates** - 12" x 12" x 3/4" plywood nailed each side, to the top of posts to ease secure the posts to header.
 - **Wedges** two wooden incline planes **married** together and placed under the bottom of the post. They are simultaneously tapped together until the shoring system is under compression and resists the weight of the structural materials above.
 - 2x wedges are more stable than 4x wedges. 2x wedges do not allow for as much adjustment, but they are preferred due to their better stability.
 - **Half-Gusset or Cleat** – 6" x12" x 3/4" plywood or 2x4x18" nailed on one side to connect bottom of post to sole after wedges have been tightened

National Urban Search & Rescue Response System
Structural Collapse Technician Training



The "T" Shore

- INITIAL SAFETY SHORE
- STANDARD "T"
- TEMPORARY SHORING
- TYPICAL HEADER LENGTH = 36"
- TYPICAL SOLE LENGTH = 24" to 36"
 - (typical same as header, can be 24" on slab)
- MAXIMUM HEIGHT IS 11 ft
- Load must be centered on the post or it is **UNSTABLE!**

SCT2b Slide 25

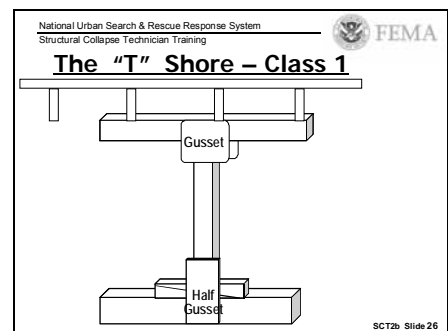



THE "T" SPOT SHORE (continued)

"T" SPOT SHORE

OH-T
08\06

CLASS 1 SHORE

Position the HEADER & SOLE PLATE across the floor and ceiling joists and align the POST under the joists

Prefabricate Post & Header, then install on Sole

Temporary shore ONLY until
a complete shoring system can be erected

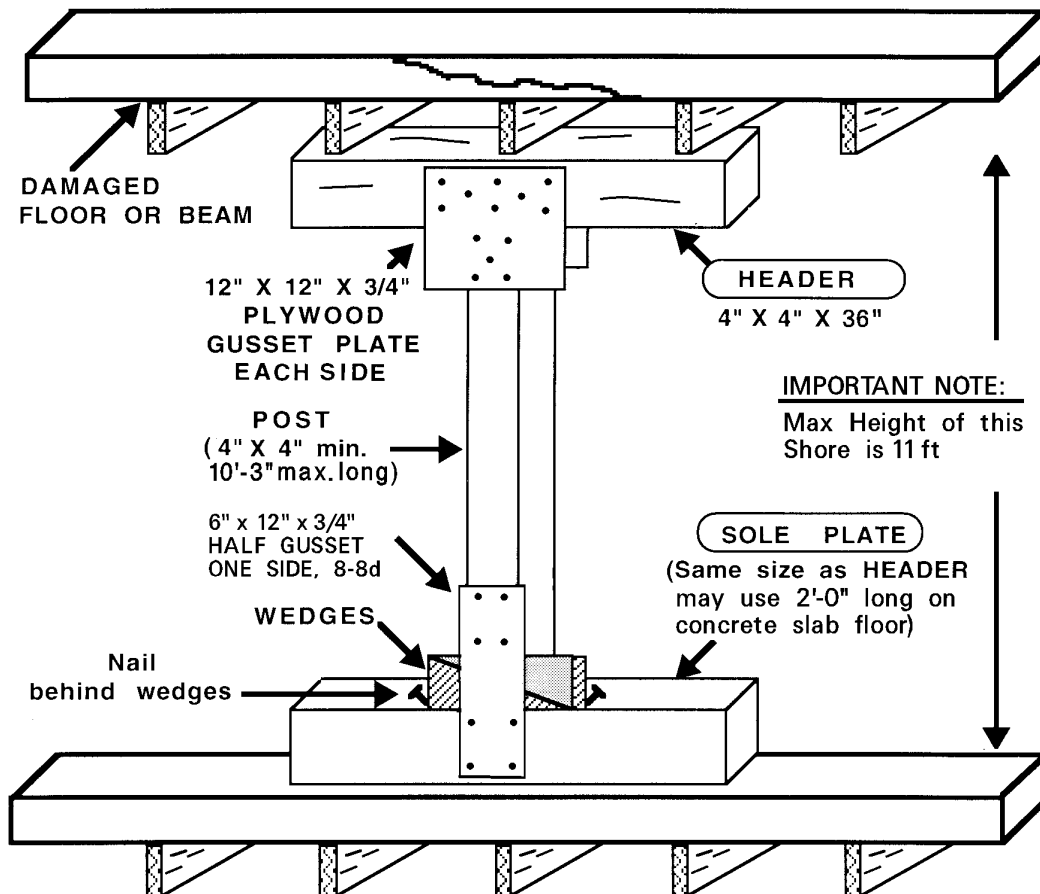

IMPORTANT NOTE:
Max Height of this
Shore is 11 ft

DESIGN LOAD
1,000 TO 4,000 Lbs
BASED ON UNKNOWN
STABILITY.

LOAD MUST BE
CENTERED ON POST

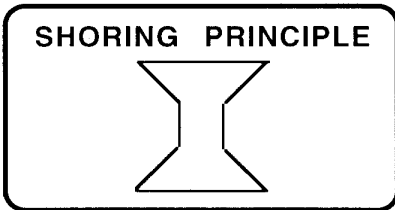

"T" SPOT SHORES CAN
BE CONSTRUCTED
W/ PNEUMATIC SHORES,
ELLIS CLAMPS, & POST
PIPE SCREW JACKS



THE "T" SPOT SHORE (continued)

HOW TO CONSTRUCT THE "T" SHORE

1. Determine where Spot Shores should be built in order to quickly reduce risk. (Prior to building more stable shores).
2. Determine overall height of area to be shored and remove least amount of debris required to place shore.
 - 4x4 post should be 10'-3" max long, so the Total Height of the shore is not more than 11 feet
3. Measure and cut header, sole & post (remember to deduct header, sole and wedge height when cutting post)
4. Prefabricate "T" shore as follows:
 - Nail post to header at its center,
 - Place 12"x 12" full-plywood gusset plate over joint and nail into position.
 - The post will get 5 nails and the header will get 8 nails.
 - Flip over and nail other gusset in position, utilizing the proper 5 and 8 nail pattern
 - **NOTE; In the past a "T" shore with a 4' header and 18" x 18" gusset plates has been allowed. The 4 ft header makes the T more unstable, and would, also be less portable. Therefore, use of a 4 ft header is not recommended. If a longer header is needed, use a 2 Post vertical Shore, as shown following the Vertical Shore**
5. Place "T" in position with the shore centered under the load.
6. Slide sole plate under "T" and wedge in position
 - Length of sole plate is typically made same as header, except on concrete floors a 2 foot length may be used.
7. Check shore for straightness and stability and tighten wedges
8. Install bottom, 6"x 12" half-gusset and nail 4-8d to post & sole.

Note that a 2 x 4 x 18" cleat may be used, but 3-16d nails to post and to sole may tend to split the cleat and require stronger pounding within the Danger Zone

9. Anchor the shore to the floor beams above and nail sole plate into the floor below.

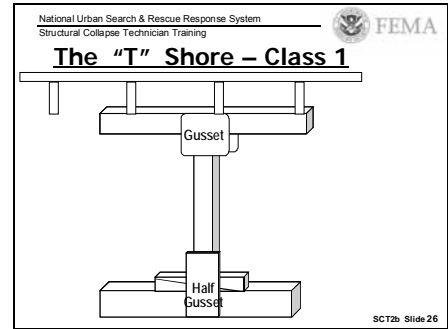



THE DOUBLE "T" SHORE

- The Double "T" shore may also be used to initially stabilize damaged floors, ceilings or roofs
- Double T Shore more stable than the T spot shore.
 - It has 2 posts with small header overhang so the load is more likely to be applied between posts.
 - The Double T is about 25 lbs heavier than the T, and a little more difficult to carry through a window
 - The mid height plywood gusset acts as a stiffening brace as well as keeping the posts aligned as the shore is being carried into place
- The size of lumber most commonly used for the Double T shore is 4 X 4 Douglas Fir. The estimated weight of the floor and its contents will help to determine the number of shores that will be required.
- Structural Components of the T shore are the same as for the T Spot Shore except that top connection uses dbl gussets each side that are 12" x 24" x 3/4"
 - There is a mid-height gusset, which may be omitted for heights less than 6 feet.

HOW TO CONSTRUCT THE DOUBLE "T" SHORE

1. Find height, cut header, post & sole as for T Shore.
2. Prefabricate Double "T" shore as follows.
 - Nail posts to header spaced 18" to 24" out to out, and centered on header.
 - One post may be tacked to header and temporarily configured to meet other post at bottom for access.
 - Place upper, double-gusset plate over joint and nail as noted below. (12" x 24" x 3/4" Dbe Gusset)
 - 14 – 8d to header and 5 – 8d each post.
 - Place mid-height, single plywood gusset and nail 8-8d to each post
 - Flip over and nail the 2nd upper gusset in position
3. Place Dbl-T in position, centered under the load.
 - If one post has been placed on slope for access, straighten it and complete nailing of Dbl-gussets
4. Slide sole plate under Dbl "T" and wedge each post in position
 - Sole plate needs to be at least as long as header
5. Check for straightness/stability and tighten wedges
6. Install bottom half-gussets & nail 4-8d ea. post & sole.
 - 2x4x18" cleats may be used w/ 3-16d ea end
7. Anchor the shore to the floor beams above and nail sole plate into the floor below.

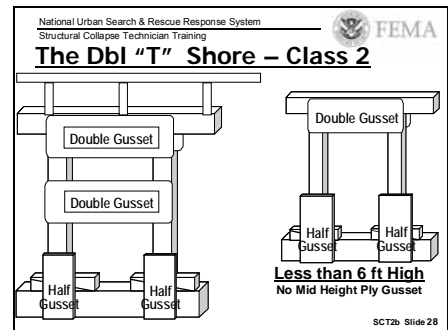
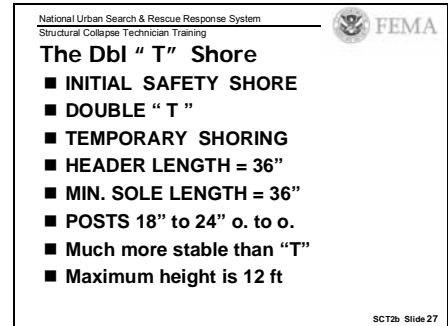



THE DOUBLE "T" SHORE (continued)

DBL "T" SHORE

O/H-Dbl T
08/06

CLASS 2 SHORE

Position the HEADER & SOLE PLATE across the floor and ceiling joists and align the POST under the joists
Prefabricate Posts & Header, then install on Sole
Double T is more Stable than T Spot Shore

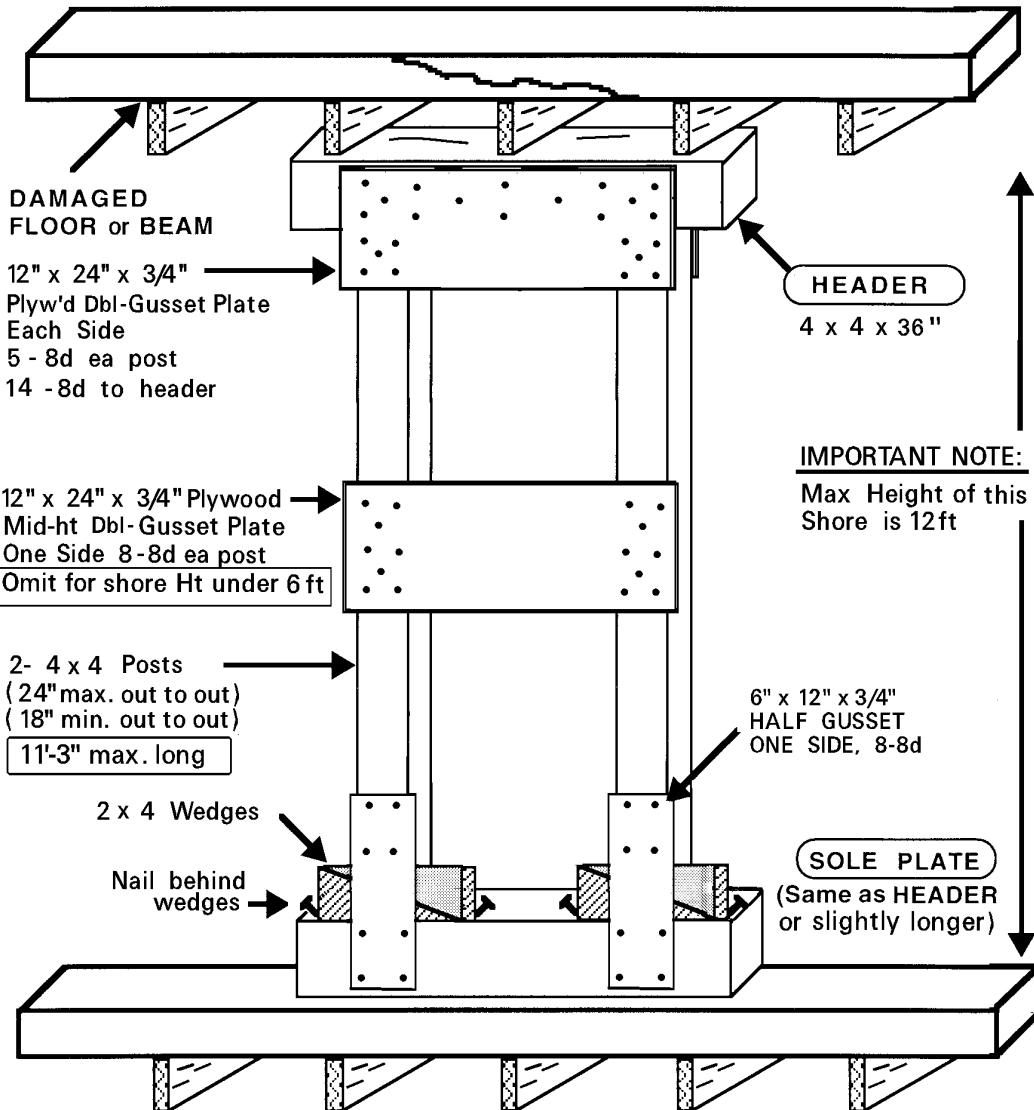

IMPORTANT NOTE:
Max Height of this Shore is 12ft

DESIGN LOAD
(based on Shore Ht.)
16,000lb for 8ft
10,000lb for 10ft
7,000lb for 12ft

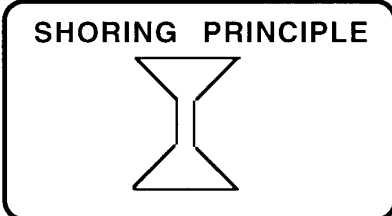

HEADER, POSTS & SOLE PLATE SHOULD BE SAME WIDTH FOR GUSSET PLATES & CLEATS TO BE MORE EFFECTIVE



THE VERTICAL SHORE

- The main purpose of the vertical shore is to stabilize damaged floors, ceilings or roofs. It can also be used to replace missing or unstable bearing walls or columns.
- The two sizes of lumber most commonly used in vertical shoring are 4 X 4 and 6 X 6 Douglas Fir (or Southern Pine). The estimated weight of the floor and its contents will help to determine the size of shoring materials and their spacing.
- Businesses and commercial occupancies with heavier structural elements and greater floor height and/or loading may require 8 X 8 or even 12 X 12 lumber. The Structural Specialist should be used to help determine the correct size and placement of shoring materials.
- Structural Components of the Vertical Shore
 - The **Sole Plate** provides a foot for the shoring system by supporting the weight being transferred from above/distributes it over a wider area.
 - The **Header** collects the weight from above and spreads it throughout the shoring system.
 - The **Posts** supports the weight being collected by the header or spreader beam and transfers it to the sole plate where it is distributed.
 - The **Sole Plate, Header and Posts** should be the same width for a more secure attachment.
 - **Wedges** two wooden incline planes **married** together and placed under the bottom of the post. They are simultaneously tapped together until the shoring system is under compression and resists the weight of the structural materials above.
 - 2x wedges are more stable than 4x wedges. 2x wedges do not allow for as much adjustment, but are preferred due to their better stability.
 - **Diagonal Braces** these double as connections and bracing for the vertical shore. They should be long enough to span its entire length and be attached to the header, each post and sole plate to lock the entire shore together as one unit .
 - A 2 x 6 nailed on both sides of the shore in opposite directions of each other to resist lateral deflection from either side.

National Urban Search & Rescue Response System
Structural Collapse Technician Training



Vertical Shore – Class 2

- SUPPORT UNSTABLE FLOORS or ROOFS
- POSTS UNDER FLOOR BEAMS
- MID-POINT BRACING > 9 ft CEIL. HT
(Posts over 8ft plus header & sole)
- 3 post type is shown – may be more posts
- (2 post type shown following this)
- Maximum slope is 6" in 10 ft

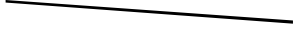

SCT2b Slide 29

National Urban Search & Rescue Response System
Structural Collapse Technician Training



Vertical Shore

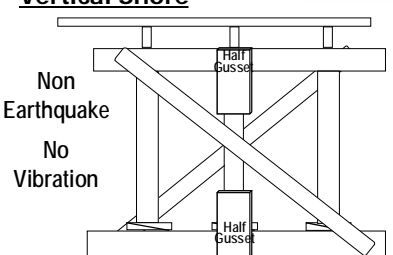

Non Earthquake
No Vibration

SCT2b Slide 30

National Urban Search & Rescue Response System
Structural Collapse Technician Training



Vertical Shore

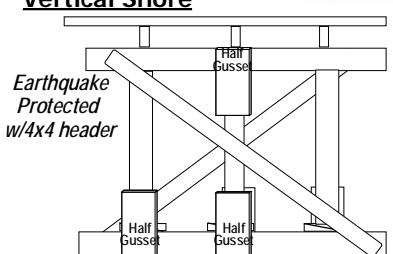

Earthquake Protected
w/4x4 header

SCT2b Slide 31



THE VERTICAL SHORE (continued)

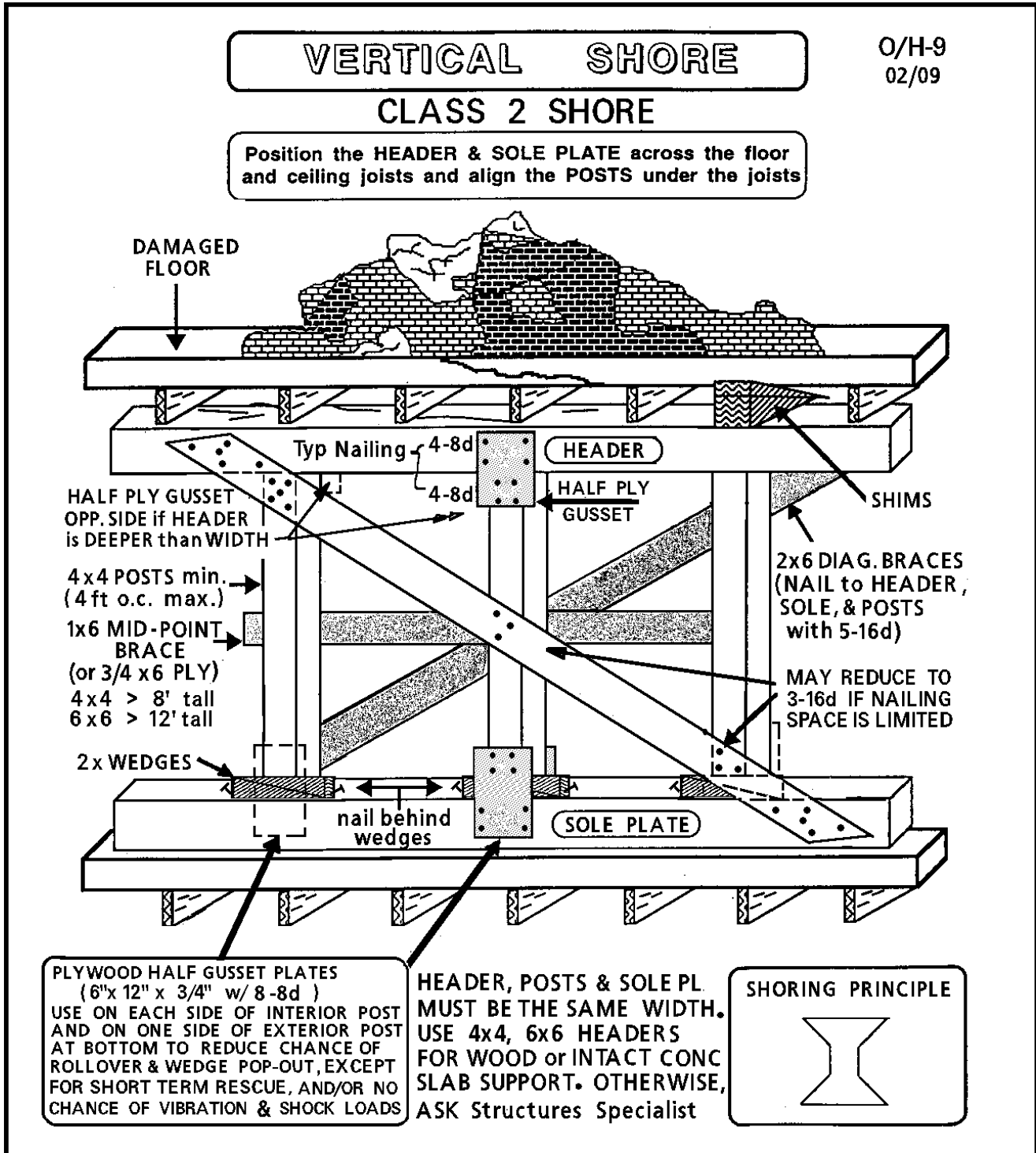



■ Structural Components of Vertical Shore (cont)

- **Mid-Point Braces** are needed when 4x4 posts are greater than 8 ft long (6x6 greater than 12 ft)
 - A 1 x 6 (or 3/4" x 6" plywood strip) nailed to the mid-height of posts on one side, unless posts are badly bowed, then both on sides.
 - If 1 x 6 or 3/4" plywood is not available, 2 x 4 or 2 x 6 may be used as mid point braces. This is the least desirable, since it must be installed after diagonal braces. (2x 4x18" cleats must be added to sides of posts to provide a step out)
 - To maintain the full capacity of posts, when 4x4 ore over 8ft long (6x6 over 12ft), one would need to build two parallel, 3 or 4 post vertical shores and place lacing (as in Laced Posts) between each post in each shore. This is normally impractical, and a better option is to use two pairs of Two Post Vertical Shores that have been made into Laced Posts
- **Half-Gusset Plates** – 6" x 12" x 3/4" plywood nailed to the top and bottom of posts to ease shore placement and secure posts to header & sole pl.
 - May use 2x4x18" Cleats, but they require 16d nails and may tend to split

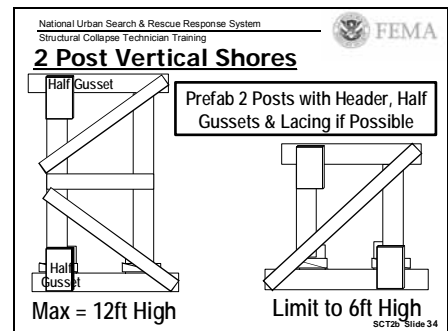
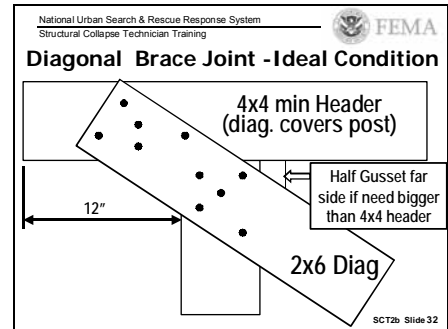

HOW TO CONSTRUCT THE VERTICAL SHORE

1. Determine where to erect the vertical shore.
 - After initial temporary shoring has been installed as needed, clear the area of debris, down to the floor, removing thick carpeting if necessary. A clearance of three to four feet wide is usually adequate.
 - If the vertical shore is to bear directly on soil, examine the ground for stability. If the earth is soft, additional supports should be installed under the sole plate to transfer the load over a wider area. (2x8, or 2x10 under sole, or if very soft, 3-2x6x18" placed perpendicular under sole at each post)
2. Lay the sole plate on the floor or ground directly under and in line where the header will be installed.
 - The sole plate should be as level as possible.

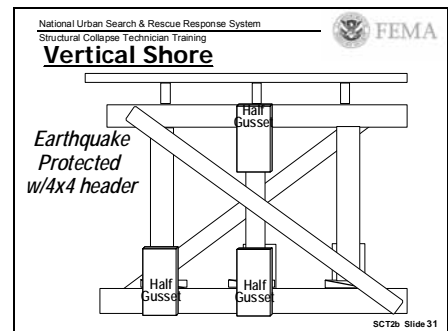



HOW TO CONSTRUCT THE VERTICAL SHORE (cont.)

3. Measure and cut the posts to the proper height.
 - Place the header on top of the sole plate.
 - With the end of tape measure on top of header where the posts are to be installed, slide tape up to bottom of structure to be shored and measure at least 3 places (deduct for the width of wedges).
4. If possible, anchor the header to the area that is to be shored, square and in line with the sole plate.
 - Secure it at the lowest point and shim the structural elements down to the header to keep it as level as possible.
5. Install the posts between the header and sole plate under each structural element to be supported.
 - The first two posts are installed at opposite ends at least 12 in. from each end of the sole plate.
 - Toenail posts to header to hold them in place.
 - Keep posts in-line & plumb w/ header & sole plate.
6. Install a set of wedges under the bottom of each post and tap them together simultaneously until the posts are under compression and tight.
 - Nail behind the wedges to secure them in place.
7. Attach the diag. braces to each side of vertical shore.
 - Mid-point braces, when needed, should be installed prior to the diagonal braces. (except when 2x material is used, then the mid-point braces are placed over the diagonals)
 - The diagonal braces should be long enough to span its entire length and be attached to the sole plate and header and each post.
 - If possible, diagonal braces should be installed in an **X** pattern on opposite sides of the system.
 - Vertical shoring systems which span a long area may require several sets of diagonal braces to connect multiple posts.
8. Attach 6"x 12" half-gusset plates to at least one side of the header and posts, if not done previously.
9. Attach half-gusset plates to at least one side of the sole plate and posts. (2x4x18" cleats may be used)
 - Half-gussets should be placed both sides to confine the wedges in all cases where any type of vibration or shock loading might occur.

National Urban Search & Rescue Response System
Structure Collapse Technician Training



2 Post Vertical Shore – Class 2

- FASTER to BUILD THAN 3 or 4 POST
- SAME AS ONE SIDE OF LACED POST
- (Can later convert a pair into a Laced Post)
- USE LACING or X BRACING
- Lacing must be 7'-6" max long so it can resist Tension & Compression
- POSTS are 4ft Max. o.c. for 4x4 (5ft for 6x6)
- Header is 1" min deep for each 1ft Span

SCT2b Slide 33

Is on Next Page



TWO POST VERTICAL SHORES

- The Limited Height Area, Two Post Vertical Shore is constructed the same as a Half High, Single Side of a Laced Post Shore
- This Two Post Vertical Shore is constructed the same as Single Side of a Laced Post Shore

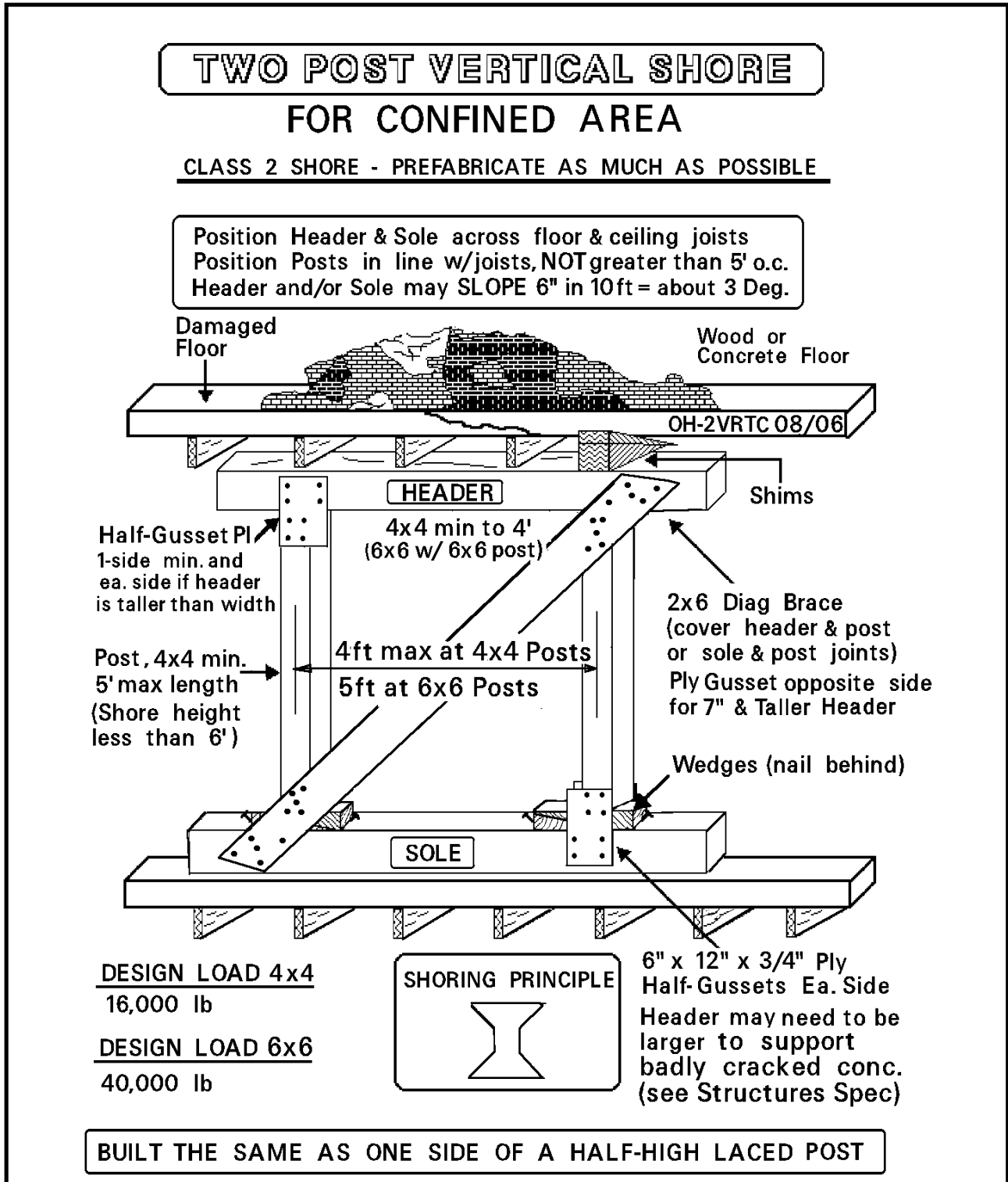



TWO POST VERTICAL SHORE

CLASS 2 SHORE - PREFABRICATE AS MUCH AS POSSIBLE

THIS SHORE IS SAME AS ONE SIDE OF LACED POST

Position Header & Sole across floor & ceiling joists
Position Posts in line w/joists, NOT greater than 5' o.c.
Header and/or Sole may SLOPE 6" in 10ft = about 3 Deg.

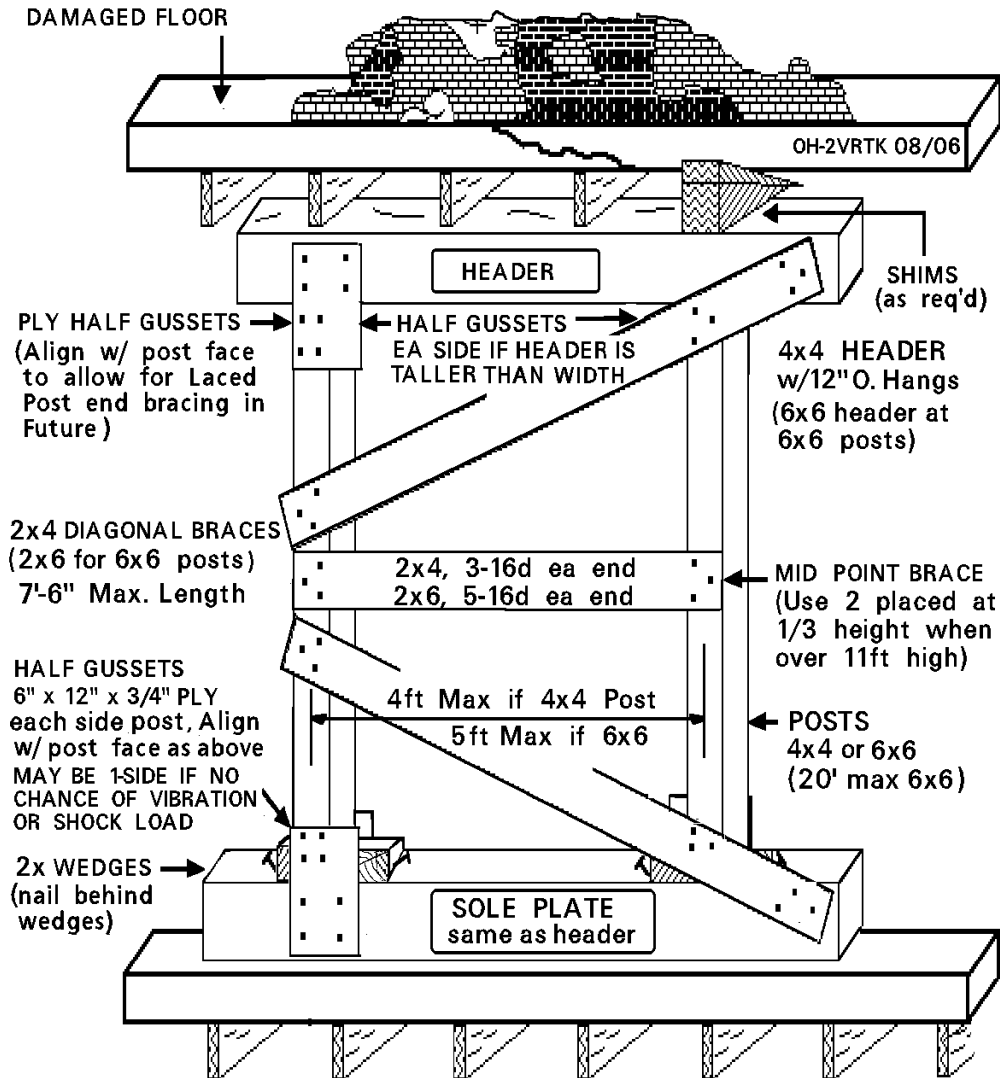

DESIGN LOAD (Shore Height)	
4x4 POST	6x6 POST
16,000 lb for 8 ft	40,000 lb for 12 ft
10,000 lb for 10 ft	29,000 lb for 14 ft
7,000 lb for 12 ft	24,000 lb for 16 ft

SHORING PRINCIPLE

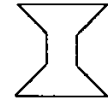

Header may need to be larger for supporting badly cracked concrete (see Structures Spec)

Max 4x4 Shore Height is 12 ft unless built as part of Laced Post



HOW to CONSTRUCT the 2-POST VERTICAL SHORE

- Determine where to erect the 2-Post vertical shore and the condition of the supporting structure and/or ground.
 - If practical, this shore should be partially prefabricated, same as for the Laced Post
 - If using 4x4 posts, space them 4 feet, max on center. 6x6 posts may be 5 feet max on center. If access is limited, Post Spacing may be reduced to 3 feet o.c.
 - The intent would be to support the damaged structure as quickly and safely as possible, but be able to later convert two adjacent, single 2-post vertical shores into a Laced Post for better stability
- Measure and cut the posts to the proper height. (Remember to deduct for header, sole & wedges when cutting posts) Also, cut the mid-brace and diagonals to proper lengths.
 - Header shall have a 12 inch overhang each end
 - Nail the header, posts, mid brace and upper diagonal together outside the damage zone, if practical.
 - Use half-gussets at Post to Header (Remember to shift the half-gusset so its outside edge is flush w/ outside of post)
- Cut the sole and wedges. Sole is same length as header
- Place 2-Post Shore in position, centered under the Load.
- Slide sole plate under shore and tap wedges into position.
- Check for straightness plus stability, then tighten wedges.
- Install bottom half-gussets (or cleats) and nail properly. (Outside face of half-gusset should be placed flush w/ outside face of Posts)
- Anchor the shore to floor above and sole to floor below, if practical.

National Urban Search & Rescue Response System
Structural Collapse Technician Training



2 Post Vertical Shore – Class 2

- FASTER to BUILD THAN 3 or 4 POST
- SAME AS ONE SIDE OF LACED POST
- (Can later convert a pair into a Laced Post)
- USE LACING or X BRACING
- Lacing must be 7'-6" max long so it can resist Tension & Compression
- POSTS are 4ft Max. o.c. for 4x4 (5ft for 6x6)
- Header is 1" min deep for each 1ft Span

SCT2b Slide 33

National Urban Search & Rescue Response System
Structural Collapse Technician Training



2 Post Vertical Shores

Prefab 2 Posts with Header, Half Gussets & Lacing if Possible

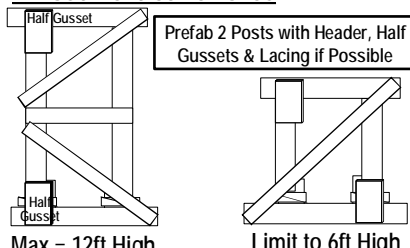

Max = 12ft High Limit to 6ft High

SCT2b Slide 34



THE LACED POST SHORE

- The main purpose of the Laced Post Shore is to stabilize very heavy, damaged floors, ceilings or roofs.
 - They can also be used to provide a safe haven.
 - It is a very stable system, since each vertical post is braced in each direction
- The two sizes of lumber most commonly used as laced posts are 4 X 4 and 6 X 6 douglas fir. The estimated weight of the floor and its contents will help to determine the size of shoring materials and their spacing.
- The structural components of a Laced Post Shore are very similar to the Vertical Shore
 - A Laced Post is essentially two, 2 post vertical shores, constructed separately and laced together.
 - Use one middle brace and two diagonals per side up to 11ft high, and two mid braces + 3 diag over 11ft high.
 - Only need one diag and no mid brace under 6ft high.
 - When 4 x 4 posts are used, the diagonal braces and center, or mid point braces, are constructed using 2 x 4 lumber for most cases.
 - Nail 2 x 4s with 3-16d each end, and take care not to split the 2x or post.
 - When 6 x 6 posts are used, the diagonals and center braces should be 2 x 6 lumber, using 5-16d each end..
 - The diagonals in a Laced Post System may be configured in a parallel or in a “K” configuration
 - The diagonals are less than 7’-6” feet long, and, therefore, they can resist both Tension and Compression forces, and may be placed in any diagonal direction.
 - The preferred configuration is four K , as shown in graphic OH-LP4K. It is also easy to remember.
 - In order to reduce the potential for Torsion Failure, it was stated in previous manuals that at least one side of each Laced Post should have its diagonals configured opposite the other 3 sides. That can lead to having too many members nailed to a 4x4 post in a single location and splitting – That layout of diagonals is no longer recommend above any other.

National Urban Search & Rescue Response System
Structural Collapse Technician Training

Laced Post Shore – Class 3

- THE STRONGEST AND MOST STABLE SHORE WE CAN ERECT
- CAN BE UTILIZED AS A SAFE HAVEN AREA WHEN NECESSARY
- 4X4’S & 6X6’S USUAL
- ONE MIDPOINT BRACE UP TO 11’ HIGH
- (2 mid point braces if higher than 11’ and
- No mid point brace if under 6ft high)
- 4’ Max. post spacing for 4x4 (5ft for 6x6)

SCT2b Slide 35

National Urban Search & Rescue Response System
Structural Collapse Technician Training

Laced Post Shore
(Up to 11 feet high – all Half Gussets)

SCT2b Slide 36

National Urban Search & Rescue Response System
Structural Collapse Technician Training

Laced Post Top Joint

SCT2b Slide 37

National Urban Search & Rescue Response System
Structural Collapse Technician Training

Laced Post Shore
(over 11 ft high, 17 ft max.)

SCT2b Slide 38



K

LACED POST SHORE

CLASS 3 SHORE • POSTS SAME SPACING EA. WAY

High capacity four post system that can be used to shore a damaged Concrete Floor or Heavily Loaded Wood Floor. It is constructed similar to a pair of 2-Post Vertical Shores but laced together.

LACED POST MAY BE USED AS SAFE HAVEN

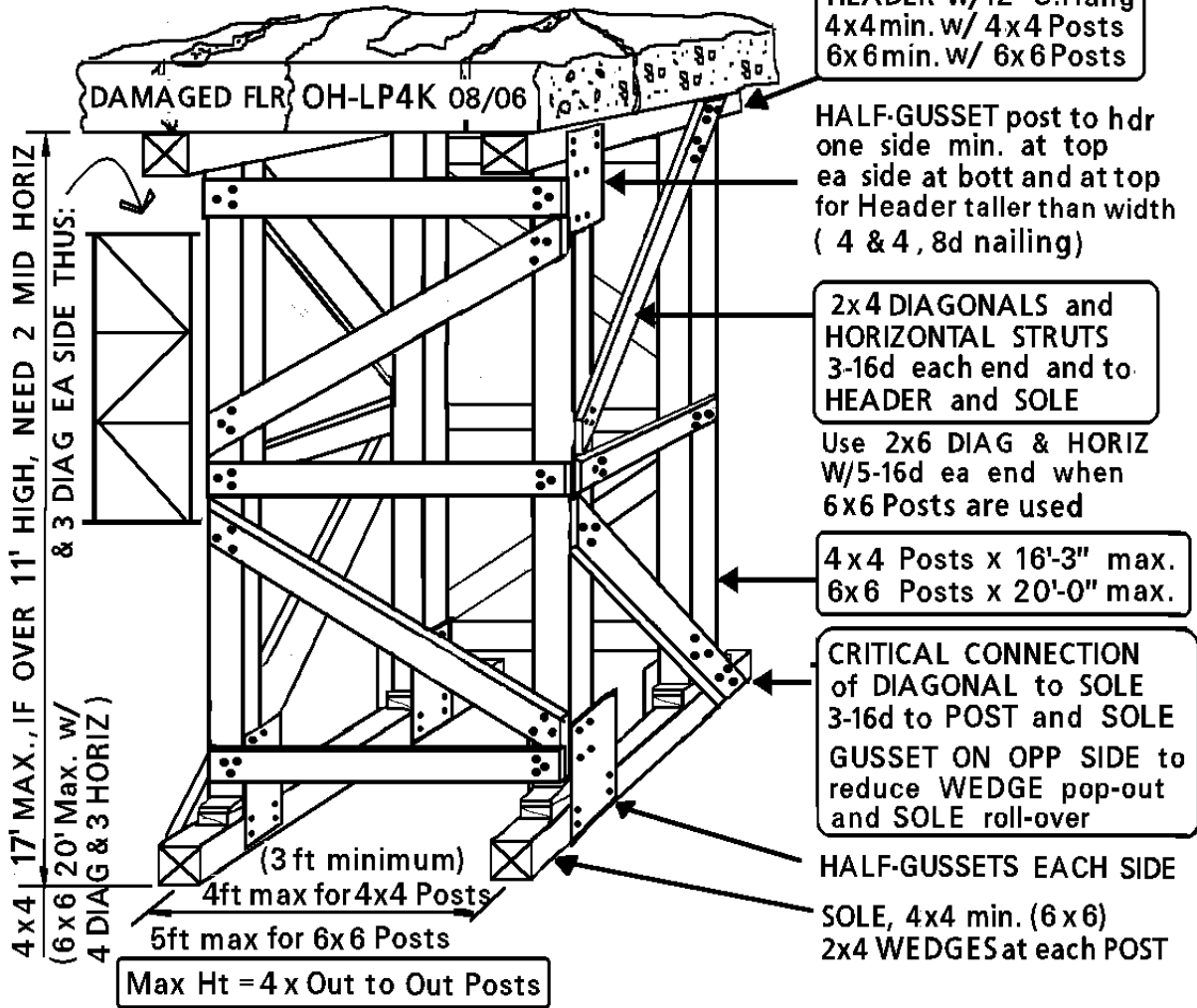

WHERE HEIGHT IS LESS THAN 6 FT ONLY NEED ONE DIAG EACH SIDE AS SHOW THUS:

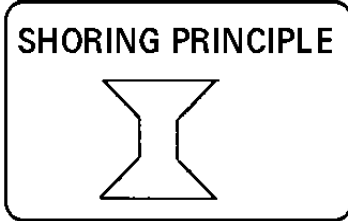
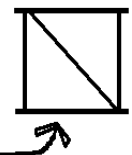

HEADER MAY NEED TO BE LARGER TO SUPPORT BADLY CRACKED CONC. SLABS/FLOORS (see Structures Specialist)

DESIGN LOAD : 4 - 4 x 4 = 32,000 lb 4 - 6 x 6 = 80,000 lb



HOW TO CONSTRUCT A LACED POST SHORE

1. Survey area and determine load displacement, and structurally unstable elements
2. Clean area to be shored.
 - Install temporary, Spot Shores (prior to clearing)
3. Determine the length of the shore.
 - Cut the header and sole plates 24 inches longer than width of the shore to allow for 12 inch overhang on each end
 - Use 6 ft long header for typical 4 ft o. to o. of posts
4. Nail posts to the header with toenails
 - Check to see if posts are straight. If not, set both with bow-out (corrected later with mid horiz-brace.)
5. Make Posts Square to the Header.
 - Do overall check by making X measurements (outside top right to outside bottom left, should be same as outside top left to outside bottom right)
 - Nail a half-gusset plate to one post/header joint. (Outside face of half-gusset is flush w/ outside face of post)
 - Nail the mid-point brace (braces) in position and re-check X measurement. If posts bow out, pull them in w/ mid-point brace (braces)
6. Measure and install the top diagonal.
 - It must overlap the post and tie into the header, use the proper nail patterns.
7. Fabricate the second section using first as template
8. Precut horizontal tie-in braces for ease of assembly.
9. Bring both sections and the sole plates into position & place the prefabricated units on top of sole plates.
10. Install wedges under posts, & check post spacing.
11. Nail horizontal braces to the two sections, both sides.
12. Measure for the diagonals, and install them in either a K or other configuration as dictated by access.
13. At the sole plate, make sure the bottom diagonal extends past the post and nails into the sole plate.
 - Place a half-gusset plate on the opposite side of this post and to each side of the other posts at the base. (outside edge of half-gusset is flush w/ outside of post)
14. Anchor the shore to the ceiling & floor, if appropriate.
15. Make sure all wedges are snug and the proper nail patterns are done.

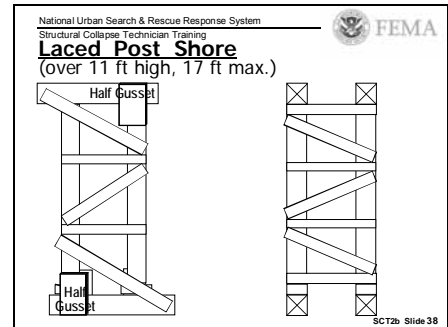
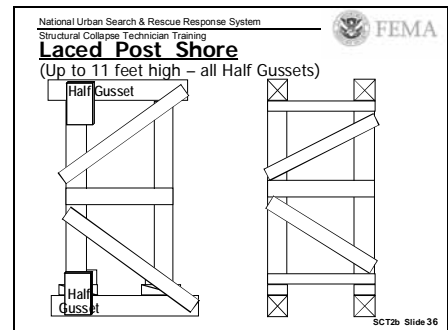



SLOPED FLOOR SHORES

- The main purpose of the Sloped Floor Shore is to stabilize damaged floors, ceilings or roofs that have collapsed into a sloped configuration
 - Vertical shores may be used to support floors with slopes up to 5% (6 inches in 10 feet).
- This shore is essentially a two-post vertical shore system, constructed with the posts placed perpendicular to the sloped surface or placed vertical. (They are connected together like a laced post)
 - These shores should be built in pairs and laterally braced in two directions, to make them Class 3 Shoring Systems.
 - Posts in each shore should be 3 to 5 ft on center, and shores may be spaced from 4 to 8 ft on center
- The posts may be 4 x 4 and 6 x 6 Doug. Fir.
- Sloped Floor Shores can be configured in two ways
 - Perpendicular Bearing Method is used when shoring a floor slab that is hinged off remaining structure or otherwise restrained from sliding. At this time only the Type 2 Shore is recommended. The Type 1 Shore requires digging-in its base and is not recommended
 - Type2 is constructed on hard surface like concrete or paving, but also on soil if 3-2x6x18" are placed under the sole at each post
 - Sloped Friction Method is used when floor slab is free to slide, and one type is used for on soil or hard surfaces.
- Cribbing may be built to support a sloped surface
 - The crib is built into the slope by adding nailed, full width shims in various layers, so the top members end up flush and tight against the sloped surface.
 - Limited clobbering to 4 ft high and a 30% slope.
- Horizontal and diagonal bracing should be placed between pairs of Sloped Floor Shores, same as for Laced Posts for shores spaced not more than 5 ft o.c.
 - When spaced 5 ft to 8 ft o.c., the bracing should consist of 2 horizontals plus X bracing as for Raker Shores.
- When these shores are under four feet tall, one may use 3/4" plywood strips (12" to 24" wide x 5 ft long) as the lateral bracing between pairs of shores.
 - Nail plywood to posts w/ 8d @ 3" in 2 rows, and the plywood should extent to within about 12" of the top & bottom of shore.

National Urban Search & Rescue Response System
Structural Collapse Technician Training

Sloped Floor Shore – Class 3

- Must be erected in pairs and cross braced
Post spacing is 4ft max. 4x4 (5ft max. for 6x6)
- Space shores from 5ft to 8ft apart
for 5 ft spacing, cross brace like Laced Posts,
more than 5ft, cross brace same as for Raker Shores
- Erect Posts "Perpendicular" to the floor, where concrete floors remain attached (Type 2)
- Erect Posts Vertical as "Friction System" where floor is not attached, and/or prevented from sliding (Type 3)
- Use 2 - 1/2" Pins, (min.) as anchors to concrete
- Use 2 - 1" Pins, (min.) as anchors to soil

SCT2b Slide 39

National Urban Search & Rescue Response System
Structural Collapse Technician Training

Sloped Floor Shores
vs. Box Cribbing

- Cribbing should be used only if Slope of Floor is less than 30% (3 ft in 10 ft, or approx. 15 degrees)

and

- If Max. Height of Shore is 4 ft or less

SCT2b Slide 40

National Urban Search & Rescue Response System
Structural Collapse Technician Training

Sloped Floor Shore
Perpendicular method
(add 3-2x6x18" under each post on soil)

Half Gusset
Type 2
(Type 1 was omitted)
Wedges are Optional

SCT2b Slide 41

National Urban Search & Rescue Response System
Structural Collapse Technician Training

Sloped Floor Shore
Friction method
(add 2x6 flat under Sole on Soil)

Half Gusset
Type 3
Wedges are Optional

SCT2b Slide 43

National Urban Search & Rescue Response System
Structural Collapse Technician Training

Slope Floor Lacing

2x6 or 2-2x4

Shores up to 5 ft O.C.

SCT2b Slide 44



SLOPED FLOOR SHORES – TYPE 2 ON CONCRETE, PAVING or SOIL

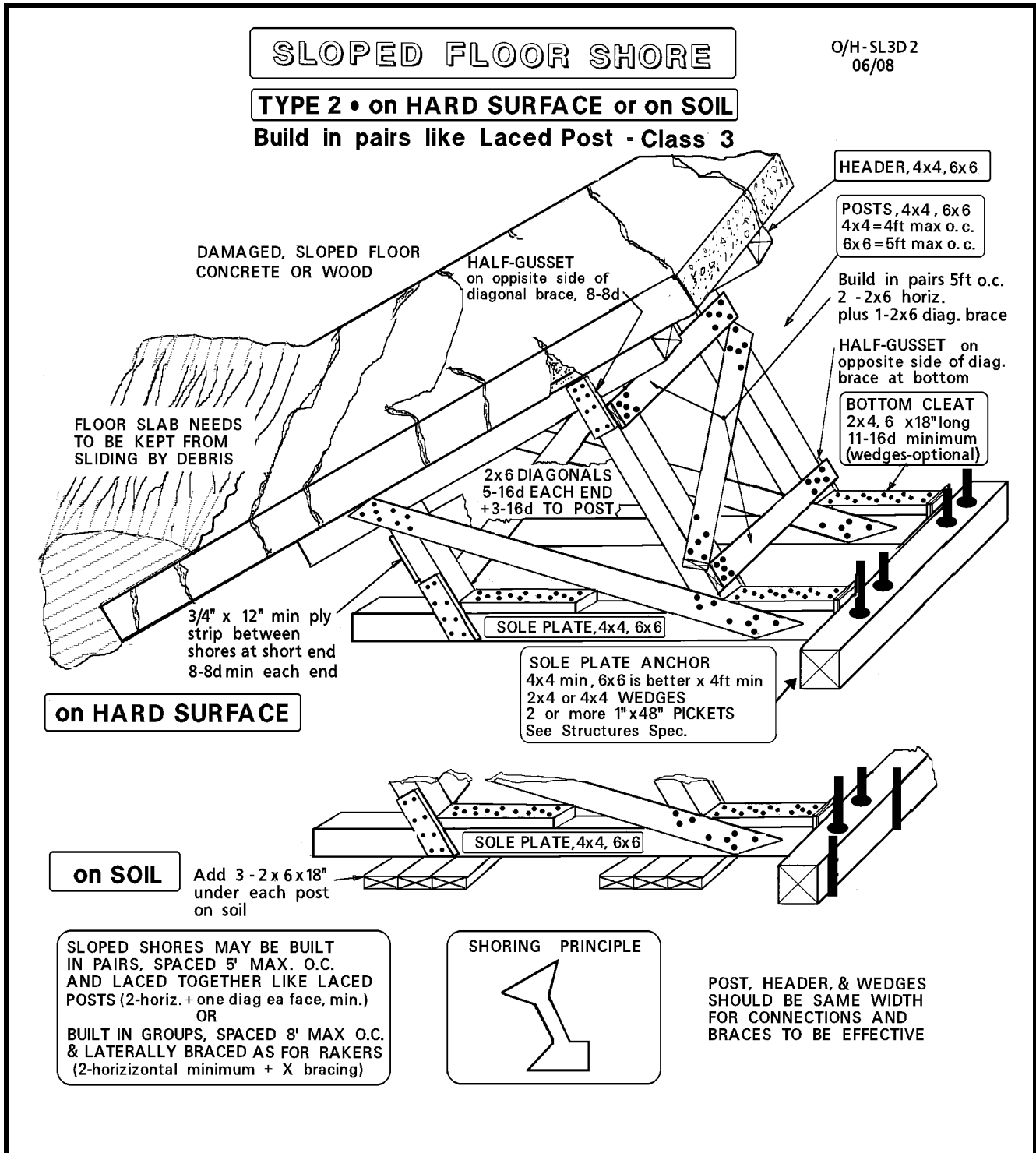



HOW TO CONSTRUCT A TYPE-2 SLOPED FLOOR SHORE (On Concrete, Paving or Soil Surface)

1. Survey area and determine load displacement, and structurally unstable elements
2. Clean area to be shored.
 - Install temporary Spot Shores if required.
3. Find length and width of shore and post locations.
 - Headers must overlap at least 12 inches.
 - The sole plate is at least 24" longer at the base of the back post. (add 3-2x6x18" under sole at each post on soil)
 - These shores should be built in pairs, spaced no more than 8 feet on center. (5 ft if using Lacing type bracing)
 - Install the header/sole plates, and anchor header.
4. Measure and install the two posts
5. Anchor to the header, and drive the bottoms up tight
6. Place the bottom cleats tight against the 1½" return cut on the posts and install proper nail patterns. (Note that wedges may be used between the post and bottom cleats, but they tend to interfere with the placement of diag. Brace. **Posts can usually be driven tight without wedges**)
7. Anchor down the sole plate.
 - Anchor sole using drilled in anchors or large rebar to anchor to concrete or paving, based on Structure Specialist recommendations.
 - Alternate Sole anchor using Sole Plate Anchor system shown with Rakers.
8. Measure for diag. braces inside & outside each shore
9. Install the 2x6 braces in position and nail into posts, header, and sole plate.
 - Half-Gusset plate (or use 2x cleats) the opposite side of the posts, top & bottom, using the 4 & 4 nail pattern.
 - Need to place half-gussets to clear horiz. and diag. Braces (installed next) or use 2x cleats instead of half-gussets
10. Brace the two sections together, same as in Laced Posts or Raker Shores (depending on spacing).
 - Both posts in order to tie the 2- sections together.
 - You may use a wide piece of ¾" plywood (12" to 24" wide) if Shore is too short to fit X braces. It's usually easier to place ply. on the inside of posts
11. Attach shore to floor and ceiling, if practical.

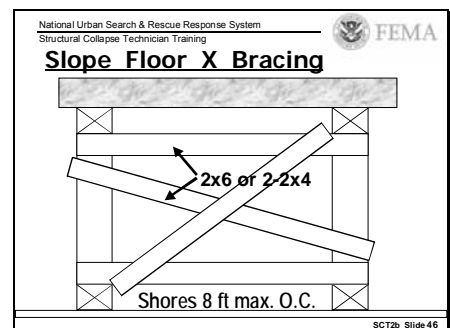
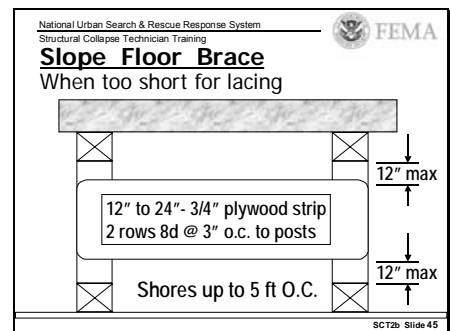
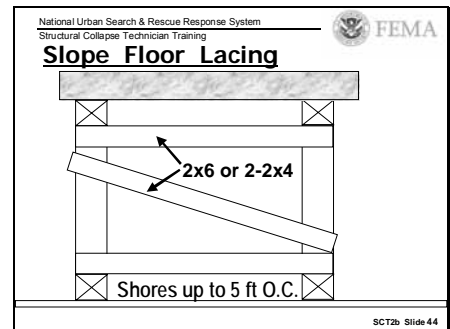
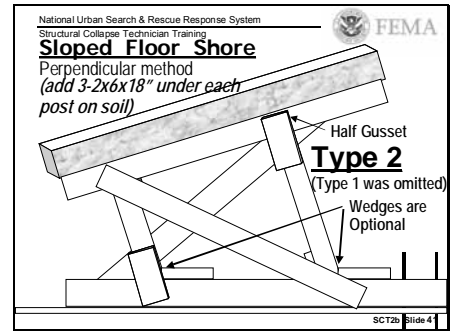



SLOPED FLOOR SHORE

O/H-SL3D.3
06/08

TYPE 3 • on HARD SURFACE or on SOIL

Build in pairs like Laced Post - Class 3

DAMAGED CONCRETE FLOOR THAT IS NOT CONNECTED TO REMAINING STRUCTURE AND NOT EMBEDDED IN RUBBLE

2 X 6 DIAGONAL BRACES
5 - 16d each end, plus
3 - 16d each post

3/4" x 12" min ply strip between shores at short end 8-8d min each end

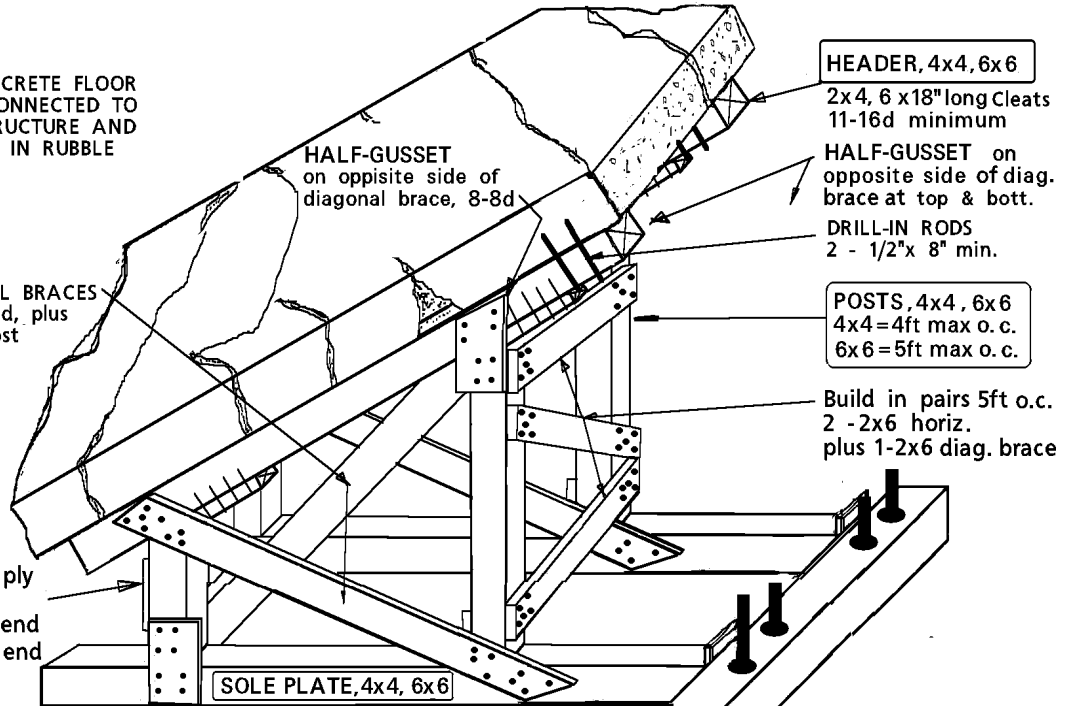

on HARD SURFACE

SOLE PLATE ANCHOR
4x4 min, 6x6 is better x 4ft min
2x4 or 4x4 WEDGES
2 or more 1" x 48" PICKETS
See Structures Spec.

on SOIL

Add 3 - 2x6x18"
under each post
on soil

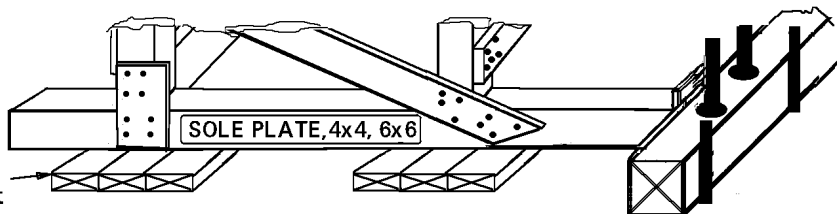

SLOPED SHORES MAY BE BUILT IN PAIRS, SPACED 5' MAX. O.C. AND LACED TOGETHER LIKE LACED POSTS (2-horiz. + one diag ea face, min.) OR BUILT IN GROUPS, SPACED 8' MAX O.C. & LATERALLY BRACED AS FOR RAKERS (2-horizontal minimum + X bracing)

SHORING PRINCIPLE

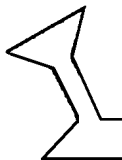

POST, HEADER, & WEDGES SHOULD BE SAME WIDTH FOR CONNECTIONS AND BRACES TO BE EFFECTIVE



HOW TO CONSTRUCT A TYPE-3 SLOPED FLOOR SHORE (On Concrete, Paving or Soil Surface)

1. Survey area and determine load displacement, and structurally unstable elements
2. Clean area to be shored.
 - Install temporary Spot Shores if required.
3. Find length and width of shore and post locations.
 - Headers overhang is 12" on lower end, but should be increased to 24" at high end.
 - The Sole Plate should extend 12 inches beyond posts (add 3-2x6x18" under sole at ea. post on soil)
 - These shores should be built in pairs, spaced no more than 8 feet on center. (5 ft if using Lacing type bracing)
 - Install header and sole plates, and anchor header.
5. Measure & install two posts. Make sure posts are vertical
6. Anchor to the header.
7. Install one 18 inch cleat for each post on underside of header with 11-16d nails (pre-install one or more of these cleats on header, when practical, to reduce nailing in Collapse Zone)
8. Place wedges in position and snug up, then place a half-gusset one side of each post, only nail to post.
9. Attached header to ceiling with at least 2 – 1/2" bar or rebar, embedded at least 3" into concrete
10. Anchor the sole plate, if required, & tighten wedges
11. Measure for diagonal braces inside & outside each shore
12. Install the 2x6 braces in position and nail into posts, header, and sole plate.
 - Half-Gusset plate (or use 2x cleats) the opposite side of the posts, top and bottom, using the 4 & 4 nail pattern.
 - Need to place half-gussets to clear horiz. and diag. Braces (installed next) or use 2x cleats instead of half-gussets
13. Brace the two sections together, same as in Laced Posts or Raker Shores (depending on spacing).
 - Both posts in order to tie the 2- sections together.
 - May use 12" to 24" wide piece of 3/4" plywood, if shore is too short to fit X braces. It's usually easier to place the plywood on the inside of the posts
14. Attached shore to floor & ceiling, if practical.

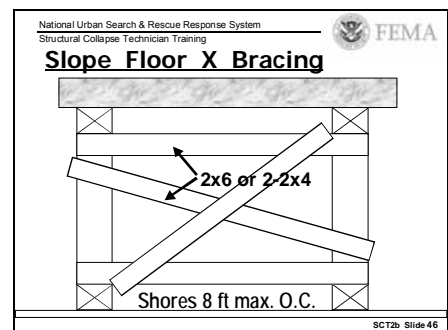
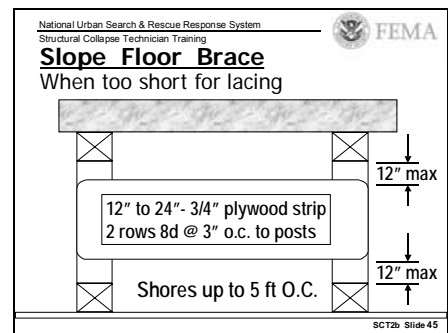
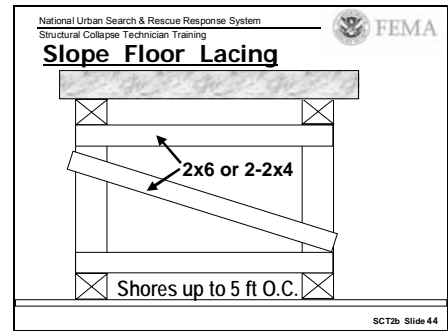
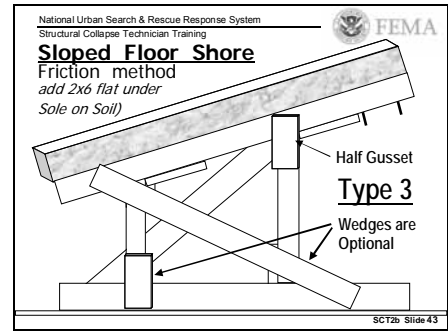



WINDOW AND DOOR SHORE

- The main purpose of the window and door shore is to stabilize a window, doorway or other access way. An extensive collapse can generate a tremendous amount of debris that blocks the primary entrances into a building and/or sometimes require a window entry.
- The window and door shore is usually installed in entry points intended for use by rescue personnel to hold up or stabilize loose headers or lintels that have lost their integrity.
- Additional load is usually exerted from above and therefore, constructed similar to the vertical shore.
 - If additional load is exerted from the side, the window and door shore should be constructed similar to the horizontal shore.

STRUCTURAL COMPONENTS - WINDOW & DOOR SHORE

- The **Sole Plate** provides a foundation for the shoring system by supporting the weight being transferred from above and distributing it over a wider area.
- The **Header** collects the weight from above and spreads it throughout the shoring system.
- The **Posts** supports the weight being collected by the header and transfers it to the sole plate where it is distributed.
 - The sole plate, header and posts should be the same width for a more secure attachment.
 - Buildings with large structural elements or openings greater than four feet usually require lumber larger than 4 X 4 for the sole plate, header and posts.
- **Triangular-Gusset Plates and Cleats** – 12"x12"x 3/4" plywood cut on diagonal (Triangular Gusset Plates) and nailed short pieces of 2 X 4 (Cleat) to both ends of the posts and struts to ease in the placement and securing the posts to the header and sole plate.
 - Cleats placed flat against the inside of the post are preferred, but diagonal cleats may be used
- **Wedges** two wooden incline planes "married" together and placed under bottom of posts or struts.
 - Simultaneously tapped together until the shoring system is under compression and takes the weight of the structural materials.

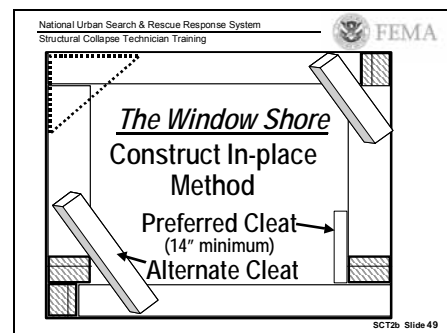
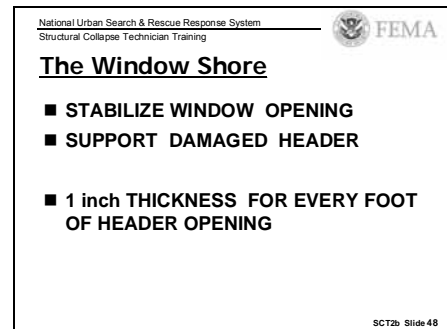



WINDOW AND DOOR SHORE (continued)

WINDOW & DOOR SHORE

O/H-11-08
11/08

THE HEADER REQUIRES 1 in. OF THICKNESS
FOR EVERY FOOT OF HORIZONTAL OPENING
(Example: 3' opening = min. 4" X 4" Header)

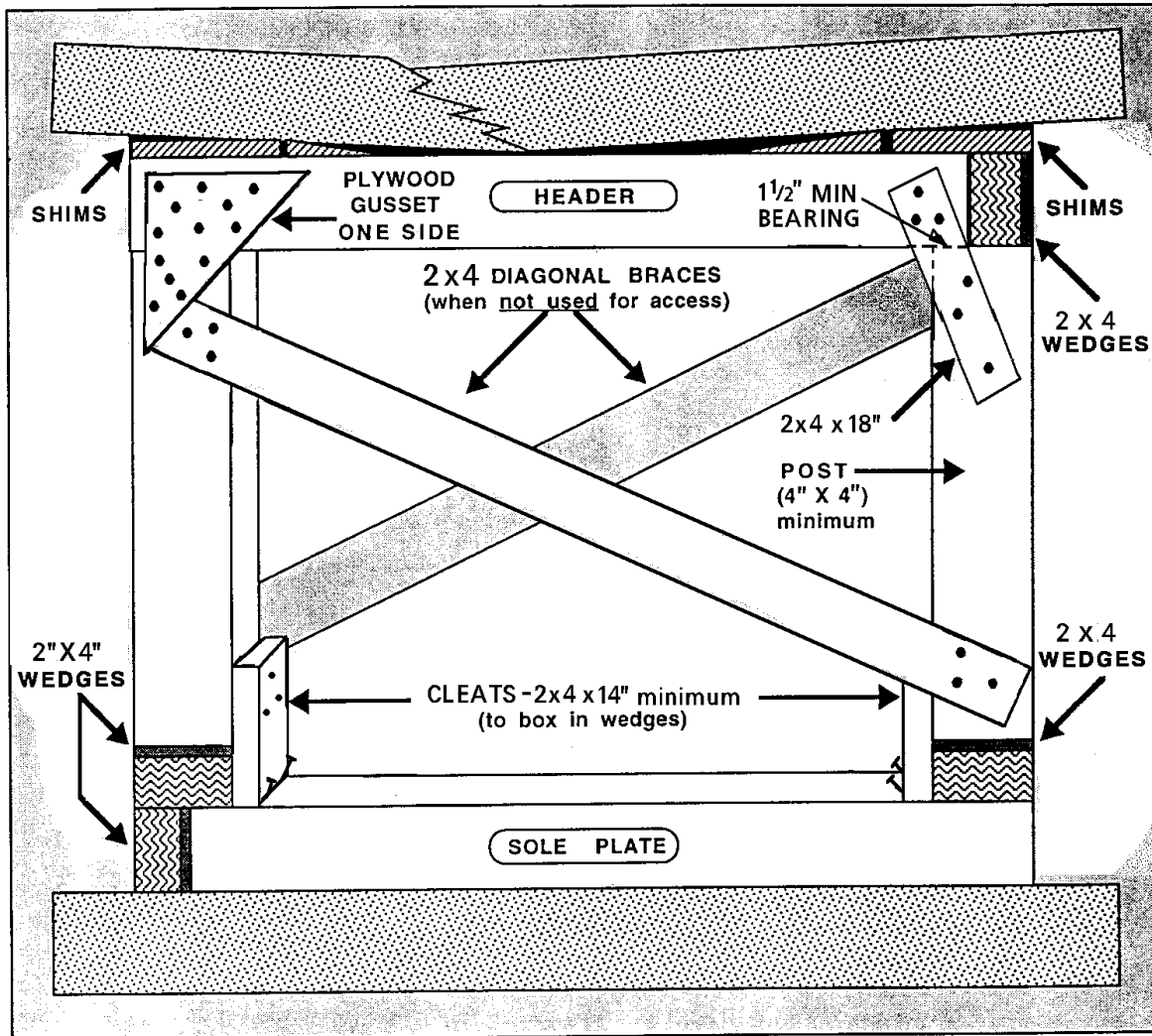

SHORING PRINCIPLE

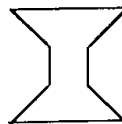

HEADER, POSTS &
SOLE PLATE SHOULD
BE SAME WIDTH FOR
DIAGONAL BRACES TO
BE MORE EFFECTIVE



STRUCTURAL COMPONENTS - WINDOW & DOOR SHORE (continued)

- **Diagonal Braces** the last items to be installed on the window and door shore when the opening is **not used** for access or egress.
 - The diagonal braces should be long enough to contact the top of the posts on one side and the bottom of the posts on the other to lock the entire shore together as one unit and support against possible eccentric loads applied to it.
 - A 2 X 4 or 2 X 6 nailed on both sides of the shore in opposite directions of each other to resist lateral deflection from either side.
- **Built-up Header** used when additional support is needed or if the opening is more than six feet wide and only 4 X 4 material is available.
 - Prior to installation of header, cut 2- 4 X 4 to proper length for header and set them one on top of the other. Place 6" wide plywood strips (as long as the headers) on each side to join the two pieces, and nail 8d @ 3" o.c. from each strip of plywood to each 4 X 4.
 - Total nailing will be 4 rows of 8d spaced 3" o.c.
 - Header will be 7" high, almost equivalent to a 4 X 8

HOW TO CONSTRUCT THE WINDOW AND DOOR SHORE

1. Determine where to erect the window and door shore
 - After initial temporary shoring has been installed clear area of debris or remaining framing material.
2. Measure and cut the sole plate to the proper length deducting the width of the wedges to be used.
3. Measure and cut the header to the proper length deducting the width of the wedges to be used.
 - Prefabricate a Built-up Header as noted above, if reqd.
4. Measure and cut the posts to the proper height.
 - Place the header on top of the sole plate.
 - With the end of the tape measure on top of the header where the posts are to be installed, slide the tape up to the bottom of the structural element to be shored on both sides deducting the width of the wedges to be used.
 - Use the shorter of the two measurements.

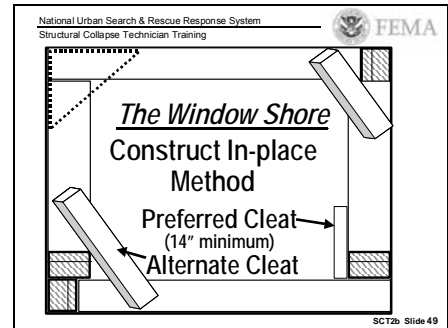



HOW TO CONSTRUCT THE WINDOW AND DOOR SHORE (continued)

5. Install the sole plate with a set of wedges at one end and tap them together simultaneously until the sole plate is under compression and tight.
 - The sole plate should be as level as possible, use shims as necessary under the sole plate.
6. Install the header with a set of wedges at the opposite end of the sole plate and tap them together simultaneously until the header is under compression and tight.
 - The header should be as level as possible, use shims as necessary above the header.
7. Install the posts between the header and sole plate and against the sides of the opening.
 - Install the first post under the wedge side of the header to prevent accidental movement if the header wedges loosen up.
 - Keep the posts in line and plumb with header & sole plate.
 - A set of wedges is installed under each post, on top of the sole plate. The wedges are then tightened to lock the shore in place.
8. Attach cleats and triangular-gusset plates to at least one side of the header and posts and nail in place.
9. Confine the wedges by placing a cleat against the inside face of each post at the bottom and nail them in place with 3-16d to each post and 2-16d toe nails to the sole plate
 - Nails may need to be Duplex for future adjustment of the wedges.
10. Install diagonal braces on the window and door shore when the opening is **not used** for access or egress.
11. Window and Door shores may also be pre-constructed as shown in adjacent slide
 - See discussion under Pre-Constructed Shores, later in this Module

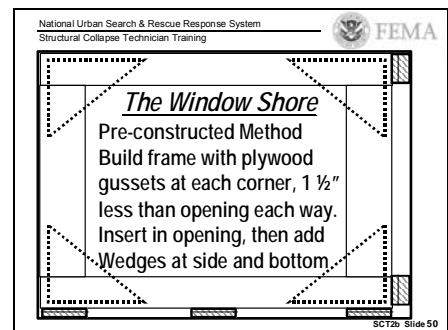
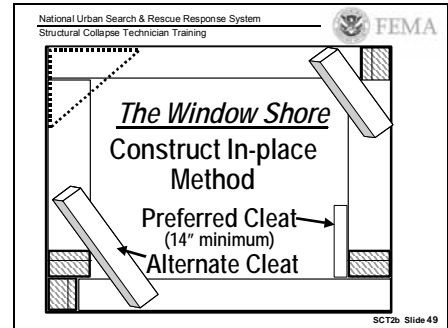



THE HORIZONTAL SHORE

The main purpose of the horizontal shore is to stabilize a damaged wall against an undamaged wall in hallways, corridors or between buildings.

STRUCTURAL COMPONENTS OF HORIZONTAL SHORE

- The **Wall Plates** provide a foundation for the shoring system by collecting the weight being transferred laterally and spreads it throughout the shoring system.
- The **Struts** supports the weight being collected by one wall plate and transfers it to the other wall plate.
 - The wall plates and struts should be the same width for a more secure attachment.
- **Cleats or Half-Gusset Plates**
 - Cleats: short pieces of (2 X 4) nailed under the struts to ease in their placement and prevent the struts from being dislodged.
 - Half-Gusset Plates: 6"x12"x 3/4" plywood nailed on at least one side of the wall plates and struts to prevent struts from being dislodged.
- **Wedges** two wooden incline planes "married" together and placed under one end of the strut.
 - Simultaneously tapped together until the shoring system is under compression and takes the weight of the structural materials.
- **Diagonal Braces** the last items to be installed on the horizontal shore when the hallway or corridor is **not used** for access or egress.
 - Should be long enough to contact both the top and bottom of the wall plates and all the struts to lock the entire shore together as one unit and support against possible eccentric loads applied to it.
 - A 2 X 4 or 2 X 6 nailed on both sides of the wall plates in opposite directions of each other to resist lateral deflection from either side.

National Urban Search & Rescue Response System
Structural Collapse Technician Training



Horizontal Shore

- STABILIZE PASSAGEWAYS
- 2 - 3 SUPPORT STRUTS

- DEBRIS WEIGHT WILL DETERMINE THE SIZE AND NUMBER OF STRUTS NEEDED

SCT2b Slide 52

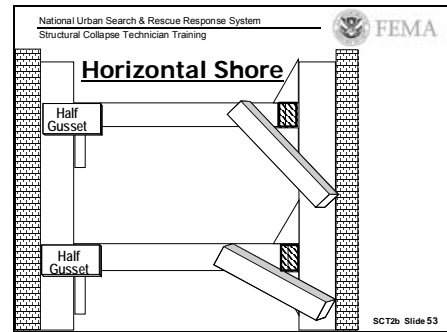



THE HORIZONTAL SHORE (continued)

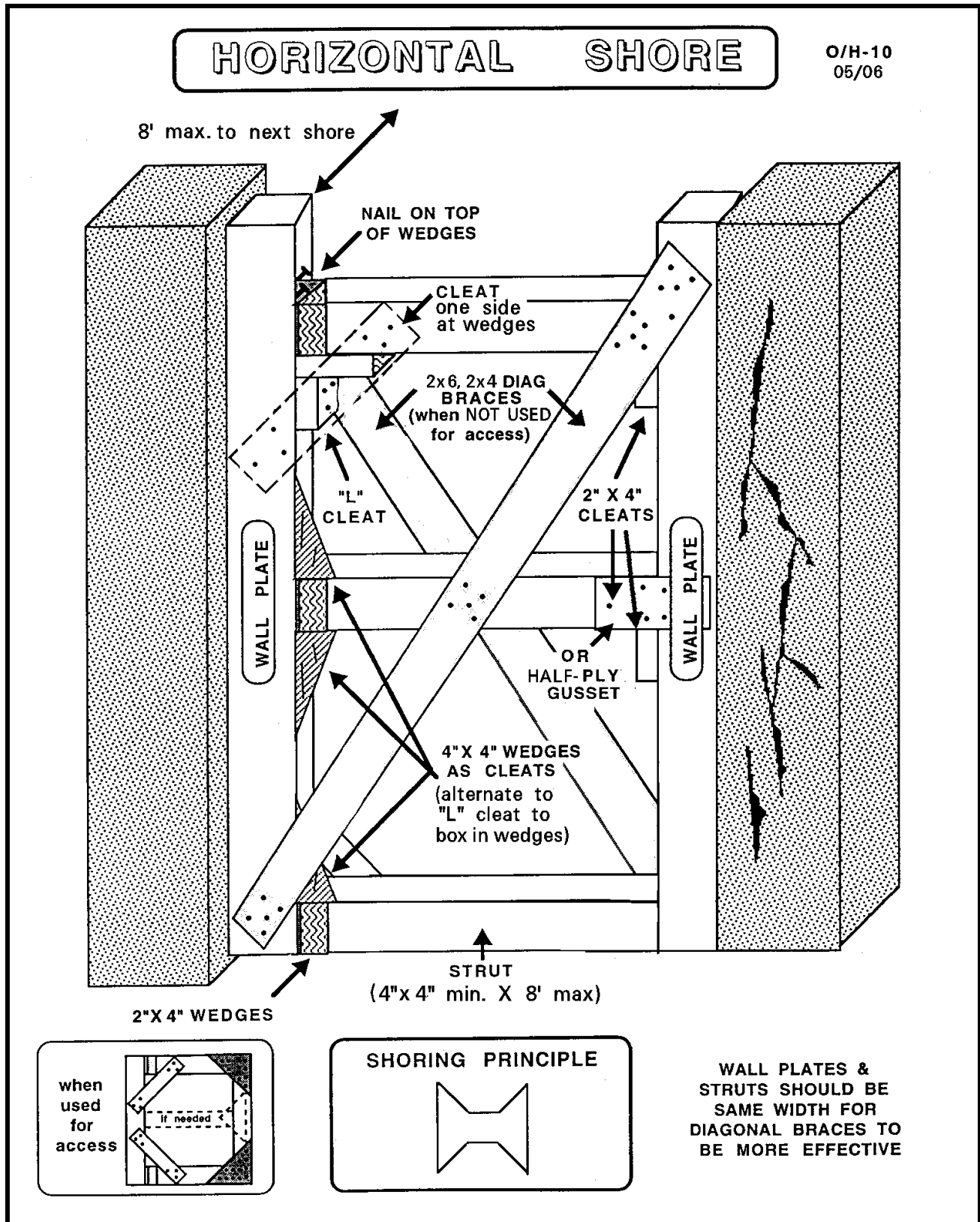



HOW TO CONSTRUCT THE HORIZONTAL SHORE

1. Determine where to erect the horizontal shore
 - After initial temporary shoring has been installed as needed, clear the area of debris.
 - A clearance of three to four feet wide is usually adequate.
2. Measure and cut the wall plates to the proper length.
3. Measure and cut the struts to the proper length.
 - Place both wall plates against the walls.
 - Measure between the wall plates where the struts are to be installed, deducting the width of the wedges to be used.
4. Place both wall plates next to each other and attach cleats to the wall plates just below where the struts will be installed.
5. Place the wall plates in the area that is to be shored, square and in line with each other and as plumb as possible by shimming any void spaces behind the wall plates.
6. Install the struts between the wall plates. Keep the struts in line and flush with the wall plates.
7. Install a set of wedges behind one end of each strut and tap them together simultaneously until the struts are under compression and tight.
 - Secure the wedges in by placing the back of a shim on top of the wedges and nail it to the wall plate or toe-nail the wedges to the wall plate.
 - Nails may need to be Duplex for future adjustment of the wedges.
8. Attach cleats or half-gusset plates to at least one side of the wall plates and struts, where aftershocks, vibrations or other shock loading may occur.
9. If possible, attach the wall plates to the walls.
10. Attach the diagonal braces to each side of the horizontal shore when **not used** for access or egress.
 - The diagonal braces should be long enough to span entire length and be attached to both wall plates and each strut.
 - When used, diagonal braces should be installed in an **X** pattern on opposite sides of the system.

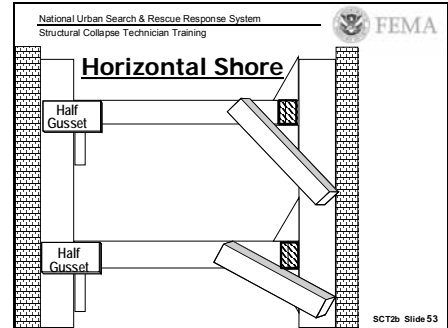



THE RAKER SHORE

The main purpose of the Raker shore is to support leaning or unstable walls and columns by transferring additional weight down the Raker, to the ground or other supporting members, and away from the wall or column.

- Full Triangular, Raker shores must always be installed in series; **at least two** must be erected in any given situation and braced together with a maximum spacing of 8 feet.
- Two general styles of Raker shores are the (Flying) Friction Raker Shore and the (Full Triangle) Fixed Raker Shore. As indicated below there are two configurations of Full Triangle, Fixed Rakers.
- The (Flying) **Friction Raker Shore – Spot Shore**
 - May be considered for initial temporary shoring due to its ease of construction and fewer shoring materials when followed with a group of well-braced (Full Triangle) Fixed Raker Shores.
 - Attach the wall plate directly to the wall to eliminate slippage/shifting and increase stability.
 - This Raker should be configured at a 60 degree angle (from horizontal) in most cases
 - Trough is preferred base - U-channel is 2nd choice
- (Full Triangle) **Fixed Raker Shore – Class 3 w/bracg**
 - All of the structural elements are tied together, making the shore one integral unit and provides the best method of anchoring and bracing, but requires the most shoring material.
 - The shore itself is stable and because of its ability to stay together this style of shoring is most often recommended for rescue situations.
 - Both type of Fixed Rakers may be constructed on concrete, paving, or soil
- The two types of (Full Triangle) Fixed Raker Shores are the solid sole plate and the split sole plate.
 - The Solid Sole Raker Shore is utilized in locations where concrete/asphalt cover the ground, or when there is open ground
 - The Split Sole Plate Raker Shore is utilized in locations where rubble is piled-up against a wall (which would be dangerous to remove) .
- Raker Shore Insertion Point
 - The insertion/support point at which the Raker shore should intercept the buildings load is within two feet below the center of the floor or roof joist.
 - Rounding-off height of the raker support point to the nearest foot will make it easier to measure.

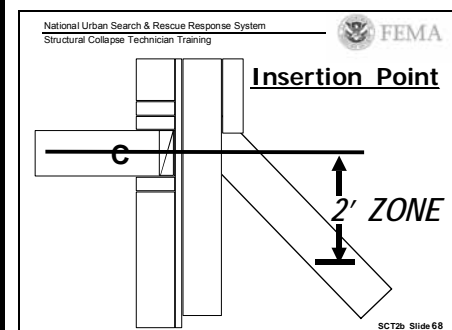
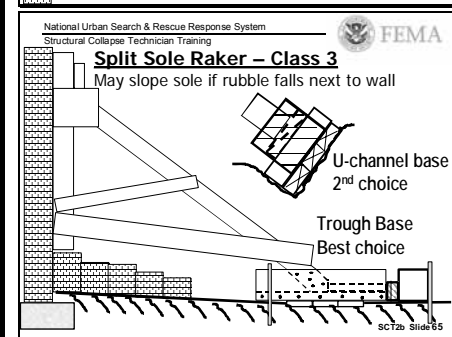
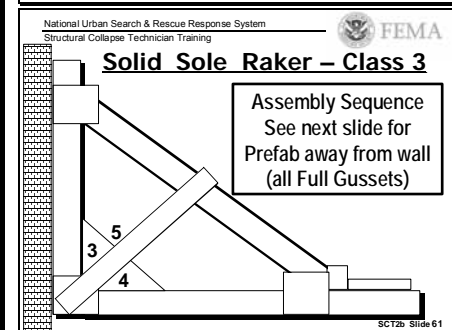
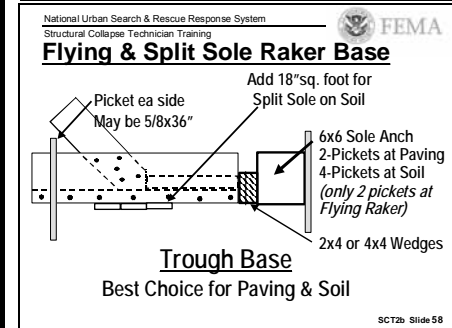
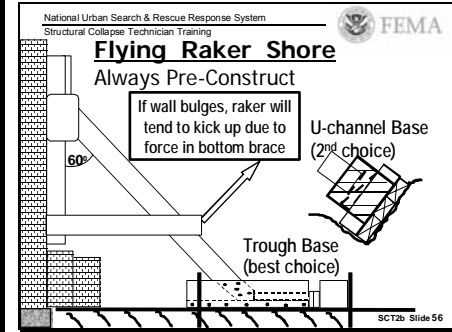



THE RAKER SHORE (continued)

- The two common angles used are 45 and 60 degrees.
 - 60 degree angle is the max. recommended angle.
 - 60 degree angle is preferred for Flying Rakers and Split Sole Rakers with U-Channel Base (better capacity of Soil)
 - 45 degree angle if most often used for Solid Sole Rakers, and may be used for Split Sole with Trough Base
 - 30 degree angles have been used to brace some structures when adequate space was available.
- Determining the height at which the raker shore needs to intersect the wall will identify the angle to work best with the available lengths of lumber.
 - A 45 degree angle raker shore requires longer lumber than a 60 degree raker shore to reach the same insertion point.
- The length of a 45-degree angle raker shore: Height of the raker shore support point in feet multiplied by 17 will give the length of the raker, tip to tip, in inches. (8 ft x 17 = 136" or 11'- 4" & horiz. distance is 8 ft).
- The length of a 60-degree angle raker shore: Height of the raker shore support point in feet multiplied by 14 will give the length of the raker, tip to tip, in inches. (8 ft x 14 = 112" or 9'- 4" & horiz. dist. is 8 x 7" = 56" or 4'-8").

RAKER DIMENSIONS TABLE (based on info above)

Insert Point	45° Raker L Inches / Ft	60° Raker L Inches / Ft	60° Horiz. D Inches / Ft
6 ft	102" / 8'- 6"	84" / 7'- 0"	42" / 3'-6"
7	119" / 9'- 11"	98" / 8'- 2"	49" / 4'-1"
8	136" / 11'- 4"	112" / 9'- 4"	56" / 4'-8"
9	153" / 12'- 9"	126" / 10'- 6"	63" / 5'-3"
10	170" / 14'- 2"	140" / 11'-8"	70" / 5'-10"
11	187" / 15'- 7"	154" / 12'-10"	77" / 6'-5"
12	204" / 17'- 0"	168" / 14'-0"	84" / 7'-0"
13	221" / 18'- 5"	182" / 15'-2"	91" / 7'-7"
14	238" / 19'-10"	196 / 16'- 4"	98" / 8'-2"
15	255" / 21'- 3"	210" / 17'- 6"	105" / 8'-9"
16	272" / 22'- 8"	224" / 18'- 8"	112" / 9'-4"
17	289" / 24'-1"	238" / 19'-10"	119" / 9'-11"
18	306" / 25'- 6"	252" / 21'- 0"	126" / 10'-6"
19	323" / 26'-11"	266" / 22'-2"	133" / 11'-1"
20	340" / 28'- 4"	280" / 23' 4"	140" / 11'-8"

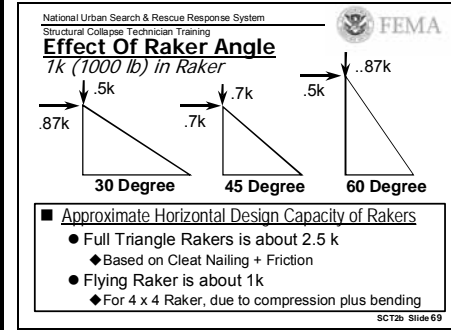

Raker Shore Angles

DEGREE	PITCH	LENGTH
45 deg	12/12	17
60 deg	12/7	14

SCT2b Slide 70

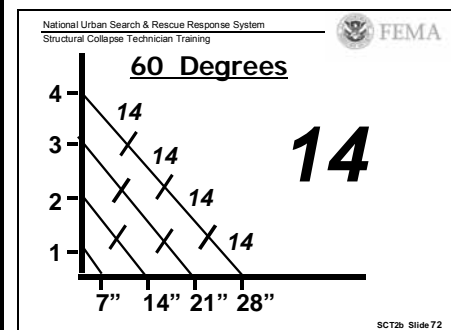
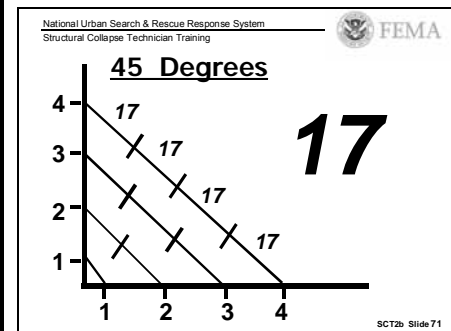

Note:
The Insertion Point may be measured from the ground, and or the top of the Sole Plate without causing much change in the Raker Angle



STRUCTURAL COMPONENTS of the RAKER SHORE

- The **Wall Plate** provides a foundation for the shoring system by collecting the load being applied laterally (horizontally) and spreads it into the shoring system.
- The **Sole Plate** receives the load being transferred both vertically and horizontally distributes it into the ground and other structural supporting members.
 - For rakers on soil, add 3-2x6x18" under sole where raker intersects (unless soil is very hard)
- The **Raker** supports the load being collected by the wall plate and transfers it to the sole plate.
 - The wall plate, sole plate and raker should be the same width for a more secure attachment.
 - Buildings with heavy structural elements or support points taller than 16 feet may require lumber larger than 4 x 4 for the wall plate, sole plate and raker. (or spliced 4x)
- The **Top Cleat** a piece of 2x lumber nailed to the top of the wall plate to keep the raker from riding up the wall plate.
 - Use 2 x 4 , twenty-four inches long, with 14-16d for 4x4 Rakers at 45 degree angles or less.
 - Use 2 x 4, thirty inches long, with 20-16d nails for 4x4 Rakers at 60-degree angles.
 - See **O/H-17**, later in this Module, for others
- The **Bottom Cleat** two foot piece of 2x lumber nailed to the top of the sole plate to keep the raker from riding back on the sole plate. **(14-16d for 2x4, at both 45 & 60 degree angles)**
 - If possible and practical, the bottom cleat and sole on the solid sole plate raker shore should be made long enough to return back to a solid object, such as an adjoining wall.
- **Wedges** two wooden incline planes married together and placed against the back end of the raker and the bottom cleat.
 - Simultaneously tapped together until the shoring system is under compression and takes the weight of the structure
 - **2x wedges are more stable than 4x, and are preferred**

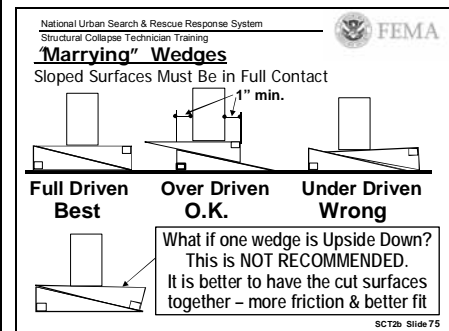
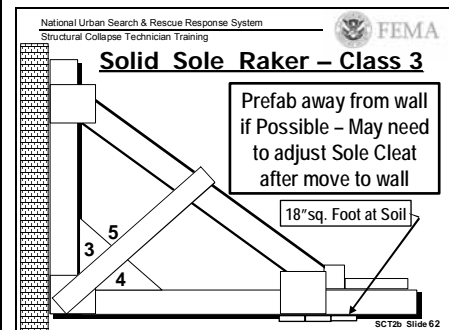
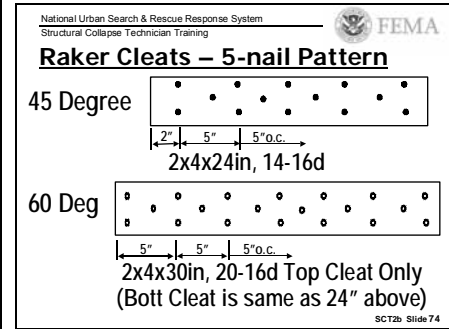



STRUCTURAL COMPONENTS of the RAKER SHORE (cont)

- **Gusset Plates** 12" X 12" pieces of 3/4" plywood nailed on both sides of the wall plate and sole plate connection and the top and bottom of the raker to prevent the them from being dislodged.
 - Split sole raker shores require gusset plates on both sides of wall plate at the top of the raker only.
- **Mid Point Braces** increase the strength of the raker by reducing the L/D ratio.
 - These braces should be long enough to reach from the wall plate and sole plate connection to near the mid point of the Raker.
 - On the solid sole Raker shore, a 2 X 6 or two 2 X 4 are nailed to both sides of the wall plate and sole plate connection and mid point on the Raker.
 - On the split sole Raker shore, a 2 X 6 or two 2 X 4 are nailed to both sides of the wall plate and just above the bottom braces connection and mid point on the Raker.
- **Bottom Braces** on split sole raker shores, a 2 X 6 or two 2 X 4 are nailed just above the ground and attached as close to the bottom of the raker as possible and the bottom of the wall plate with a fill block near the middle for additional stability.
 - Placed at the bottom of the wall plate and along the raker above the ground on the (Flying) Friction Raker Shore.
- **Trough** is the preferred foot for the Friction and Split Sole Raker when bearing on Paving or Soil
 - It needs to be anchored against a Sole Anchor w/Pickets, and existing curb, or some other reliable object. On paving, drilled-in metal anchors may be used
- **U-Channel** is second choice as a foot for the Friction and Split Sole Raker when bearing on soil
 - It is nailed to 3-2 X 6 X 18" (or 2 layers of 18" sq. x 3/4" plywood) to provide better proper soil bearing for the Split Sole.
 - It may be placed directly against soil for the Flying Raker.
 - It needs to be dug-in next to the dangerous wall, and is less desirable than the Trough

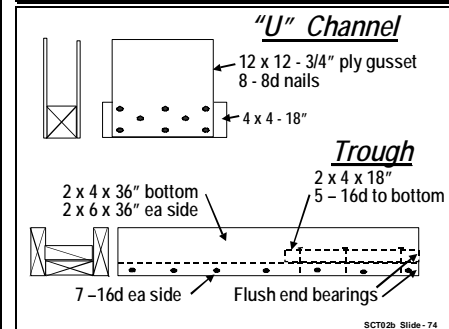
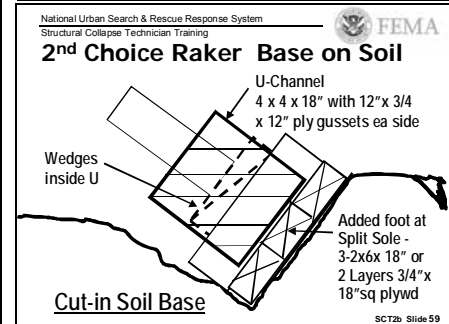
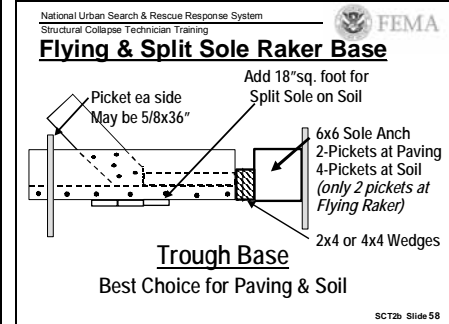
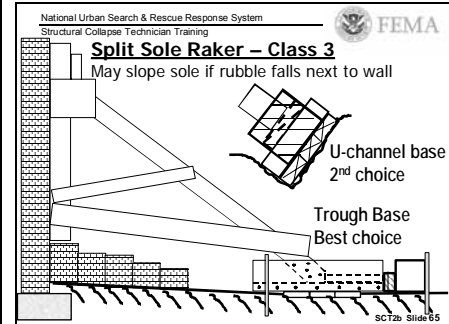
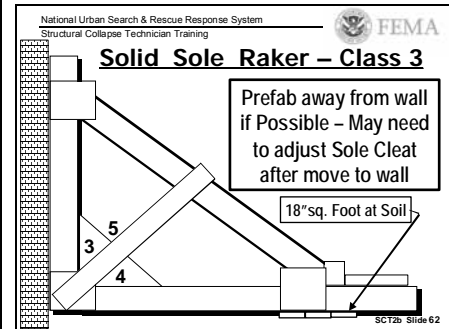



STRUCTURAL COMPONENTS or the RAKER SHORE (cont)

- **Horizontal Braces** horizontally connects the raker shores together near the top and bottom of the raker to provide additional stability to raker shore system.

 - Horizontal braces attached to the mid point of the raker increase the strength of the raker by reducing L/D ratio.
 - Splice the horizontal brace at center of raker and cover splice with half-gusset.

- **X and V Braces** connects the raker shores in an **X** or **V** pattern near the bottom and middle of the raker depending on access needs and available lumber.

 - Provides additional stability to the raker shore system and decreases the lateral movement when at least a pair are used at the beginning and end of the raker shore system.
 - This bracing should be placed no farther than 40 feet on center for a multi-raker system

- **Backing Material (Optional, Only if Needed)**

 - Plywood (Full and Half Sheets) require a minimum of $\frac{3}{4}$ " or two $\frac{1}{2}$ " sheets of plywood nailed together.
 - 2 X Lumber (2 X 8, 10 & 12)
 - Nailed, 16d & 6'o.c. to the back of the wall plate, and is used for URM walls that are badly cracked and cannot safely span between rakers, or for wood walls where it is useful to nail directly to studs and/or edge joist (or blocking) at floor line
 - Nail plywood backing to wood wall w/ 8-16d each side of raker
 - Nailed 16d@6"o.c., to the back of the sole plate can help distribute the weight of the wall over a wider area in soft or muddy soil.
 - Backing material must contact the wall at the raker support point and at the bottom of the wall plate.
 - Shims may be needed to fill void spaces.
 - Backing material can be used to attach the wall plate to the wall or sole plate to the ground.

- **Splicing the Raker Shore**

 - Length of 4x4 or 6x6 is insufficient to extend to the required insertion point, the Raker may be spliced.
 - The splice should be constructed where mid-brace and mid horizontal lateral brace intersects, .
 - The splice is often necessary for the Double Raker

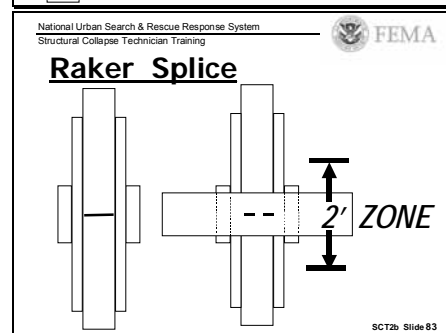
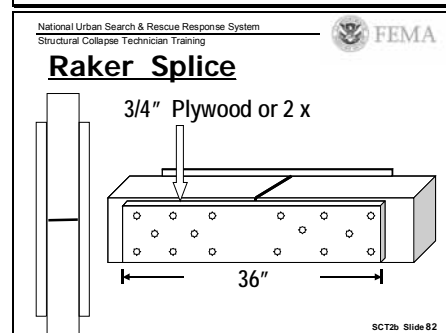
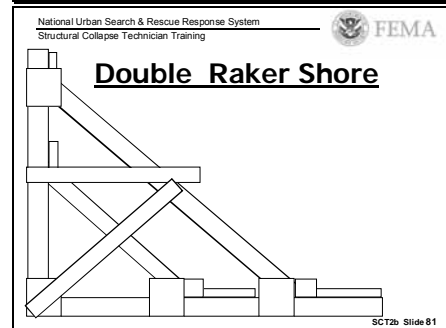
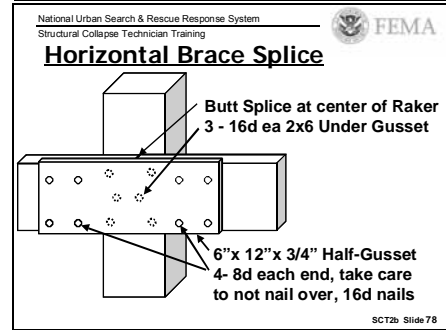
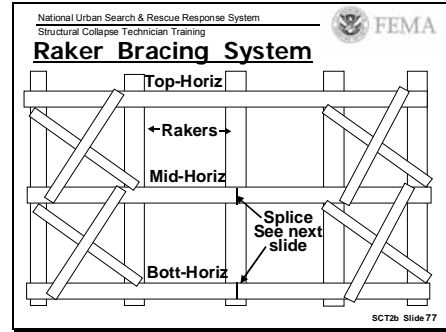



STRUCTURAL COMPONENTS OF THE RAKER SHORE (continued)

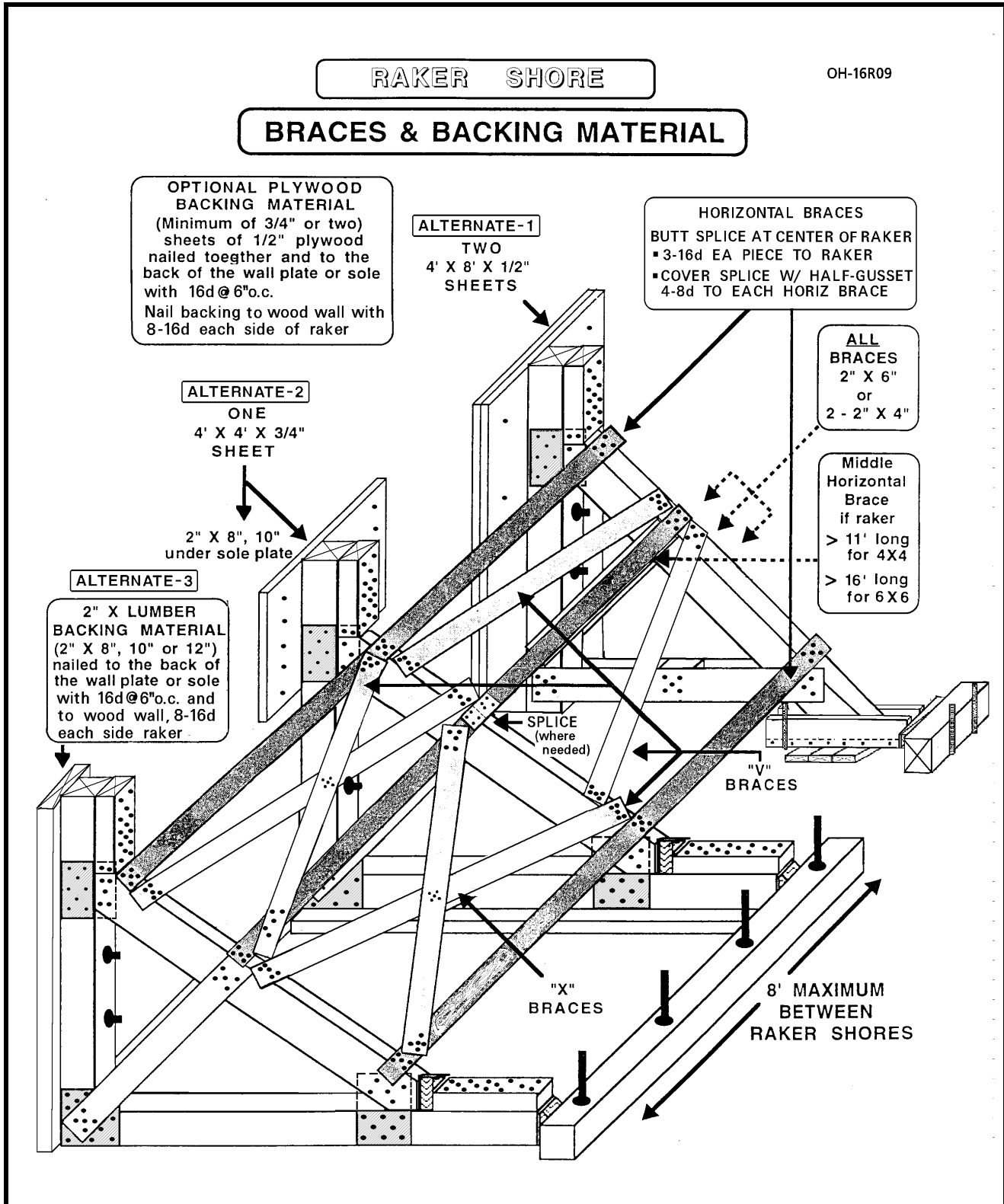



NAIL PATTERNS FOR RAKER AND OTHER SHORES

NAIL PATTERNS FOR 3/4"X12"X12" & 3/4"X 6"X12" PLY GUSSET PLATES & TRIANGLES, BRACES & CLEATS
(Use 8d nails on plywood & 16d nails on 2" lumber)

NOTE: OSB MAY BE USED AS PLYWOOD

OH-16A 08/06

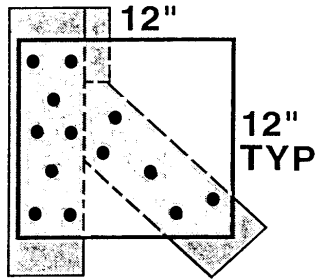

TOP OF RAKER GUSSET PLATE

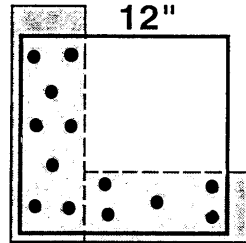

BOTTOM OF RAKER GUSSET PLATE

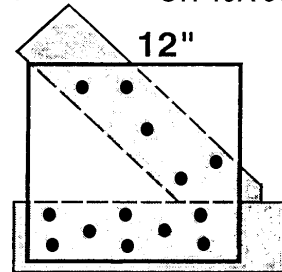

REAR OF RAKER GUSSET PLATE

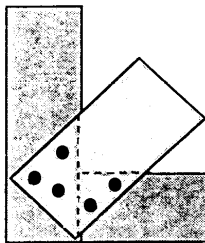

2" X 6" BRACES & CLEATS

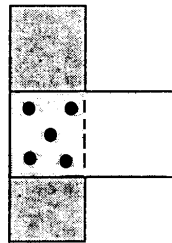

2" X 4" BRACES & CLEATS

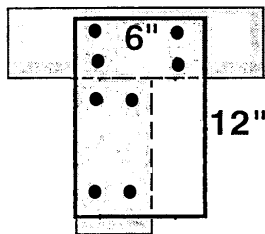

END VERT POST TOP & BOTTOM HALF-GUSSET PLATE

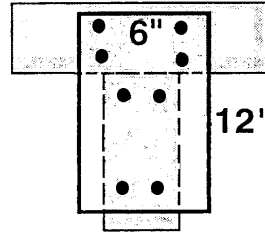

MID VERTICAL POST TOP & BOTTOM HALF-GUSSET PLATE

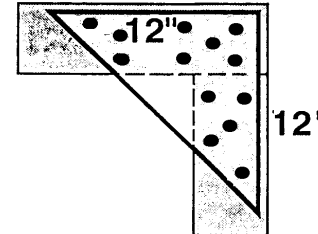

WINDOW/DOOR SHORE TOP & BOTTOM TRIANGLE GUSSET PLATE

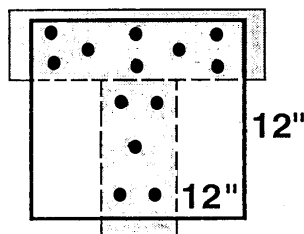

TOP OF TEE SHORE GUSSET PLATE

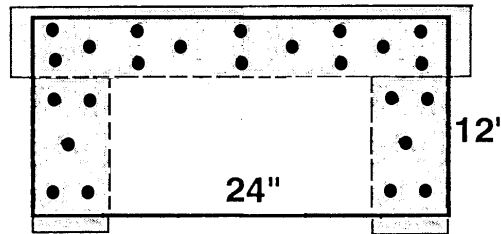

TOP OF DOUBLE TEE SHORE DOUBLE GUSSET PLATE



THE RAKER SHORE (continued)

FLYING RAKER SHORE

WITH LEVEL BOTTOM BRACE and TROUGH BASE

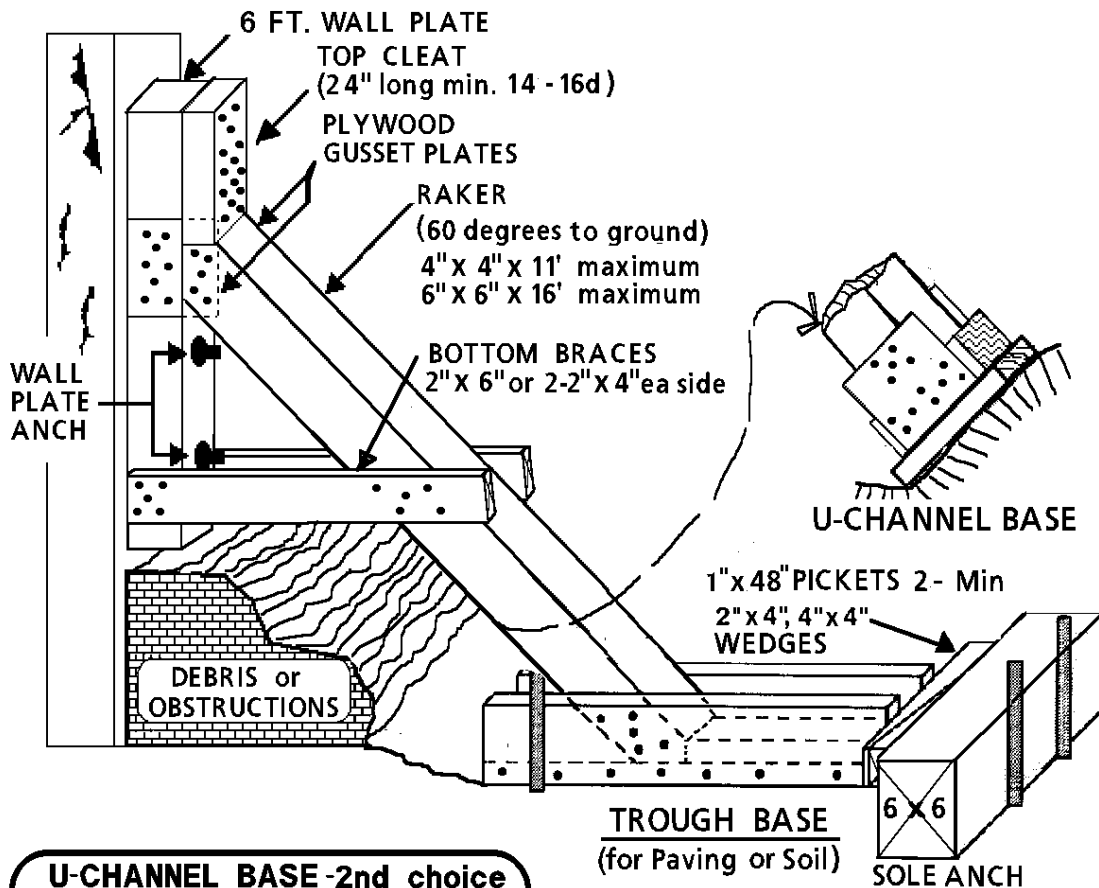

U-CHANNEL BASE -2nd choice
4" X 4" X 18" with gusset plate ea side

May use Compact Soil Under SOLE PLATE or
Wedges Under RAKER for Adjustment

Very Soft Soil SOLE PLATE
3 - 2" x 6" x 18" w/2-16d each or
2 layers 3/4" ply internail 8d at 8"
each way + nail w/3-16d to 4x4

WALL PLATE, RAKER & SOLE SHOULD BE SAME WIDTH

SHORING PRINCIPLE



HOW TO CONSTRUCT A FLYING RAKER SHORE

All shoring should be **pre-fabricated** if possible, to **Minimize the exposure of Rescue Personnel to Risk**

- The areas to be supported by rakers should be considered extremely dangerous. Temporary Flying Rakers may need to be erected prior to building more permanent, Full Triangle Raker systems.
 - Determine where to erect the Raker shores and the height of its support points. Determine height of Insertion Point.
- Flying Rakers can be erected against the wall without removing the Debris that may be piled up against it.
 - They may be used as single Spot Shores, or may be built in pairs with horizontal & X bracing added between pairs.
 - Flying Rakers should be prefabricated, fit into their Trough or U-Channel Base, wedged and/or shimmed, then attached to the wall with drill-ins.
 - In some cases the drill-ins may be omitted if the top of the Wall Plate can bear against a protrusion in brick/concrete wall. or:
 - At brick/concrete wall, Raker may be built at one edge of a window, with a single or double 2x4 (24" min w/14-16d) pre-nailed to the Wall Plate so it will bear on the bottom of Window Header (**Only if header is not badly cracked**).
- In order to pre-fabricate, cut raker, wall plate & bottom brace to proper length, & perform raker angle cuts.
 - Layout Wall Plate, Raker and Bottom Brace at selected angle (normally 60 deg raker angle), and toenail Raker to Wall Plate.
 - Nail on Top Cleat, then nail gusset to one side of this joint.
 - Nail one-Bottom Brace to Wall Plate in position to clear debris, but only tack-nail it to Raker.
 - Turn Shore over and nail-on other gusset and bottom brace (nailed to Wall Plate, tack to Raker).
- Anchor Trough (or U-Channel), then carry the partly assembled Raker into place. Snug-up the Wedges, and complete the nailing of bottom brace to Raker.
 - Make whatever connection to wall that is selected, as indicated above, and retighten the Wedges.
 - A Trough Base is used to reduce the risk of digging adjacent to the Collapse Zone or on paving or soil.

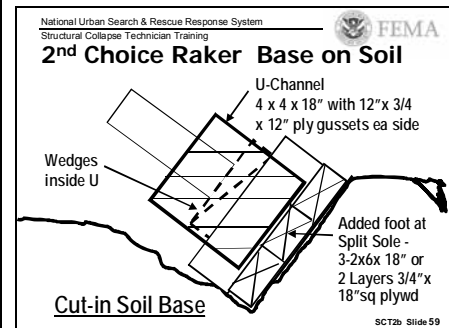
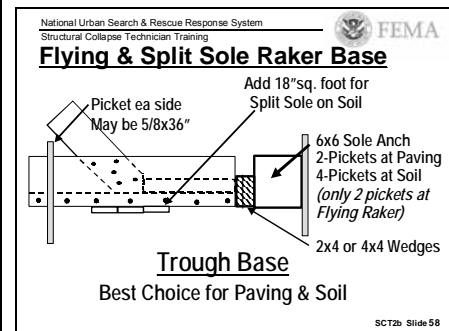
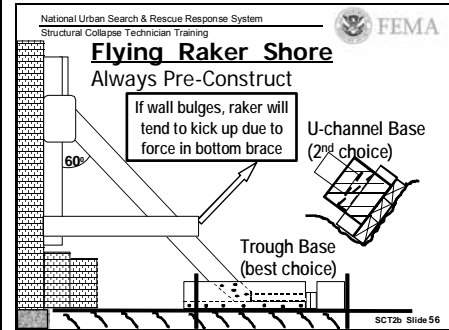



THE RAKER SHORE (continued)

RAKER SHORE

O/H-13-08
11/08

SOLID SOLE METHOD

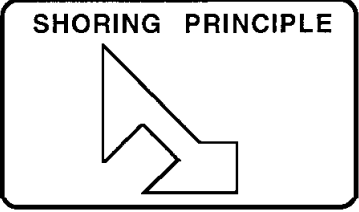
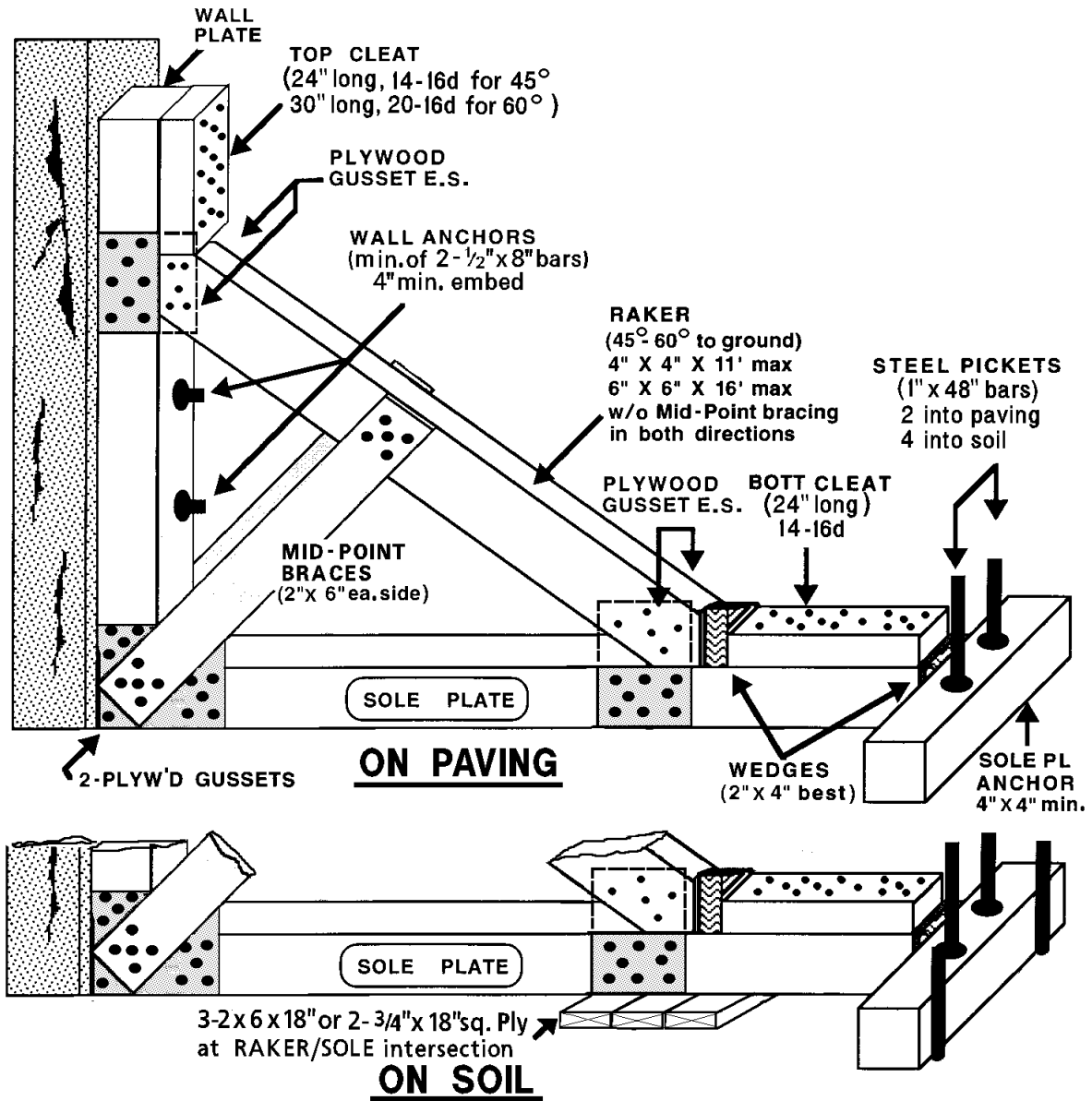

RAKER, WALL PLATE & SOLE PLATE MUST BE SAME WIDTH FOR PROPER ALIGNMENT

USUALLY THE BEST RAKER TO BUILD. MAY BE USED ON PAVING OR SOIL. ADD 18" SQ. FOOT UNDER RAKER/SOLE INTERSECTION ON SOIL



HOW to CONSTRUCT a SOLID SOLE RAKER SHORE

All shoring should be **pre-fabricated** if possible, to **Minimize the exposure of Rescue Personnel to Risk**

1. Determine where to erect the Raker shores & height of its support points. Find height of Insertion Point
 - a. After initial temporary shoring has been installed as needed, clear the area of debris.
 - b. For each Raker clear three feet wide and at least the height of the support point out from the wall.
2. Select angle of Raker, then measure and cut the Wall Plate, Sole Plate and Raker to the proper length.
 - a. Sole plate and Wall Plate must extend at least 24 inches from where the Raker intersects them to allow for the Cleats to be nailed.
 - b. Both ends of the Raker to be angle-cut with 1 1/2 " return cuts for full contact with the wall plate, top cleat, sole plate, and wedges.
3. Pre-fabricate Wall Plate, Raker and Sole
 - a. Toenail Sole to base of Wall Plate, square inside to 90 deg, and secure with bottom, full-gusset plate, one side
 - b. Layout Raker at selected angle, intersecting with Wall Plate and Sole. Then install Top Cleat and nail on gusset one side of this top joint
 - c. Nail one Sole Gusset to Raker, but not to Sole at this time, since Raker may need adjusting when moved to wall.
 - d. Mark the Sole for the approximate position of the Bottom Cleat, allowing for the Wedges
 - e. Flip Raker Shore over and nail full-gussets on opposite side, but remember to nail the Raker to Sole Gusset, to Raker only, not to Sole to allow for later adjustment
4. Carefully move the partially prefabricated Rake Shore in place at the wall and make sure it is plumb.
 - a. With Raker Shore placed against the wall, the Sole should be carefully driven-in so the Wall Plate is snug against the Wall, and the Bottom Cleat should be completely nailed, allowing space for the Wedges
 - b. Full contact must be maintained between the wall plate and the support point of the Raker, and between the base of the wall plate and the wall.
 - If the wall has bulged out, shims may need to be added near bottom of wall plate

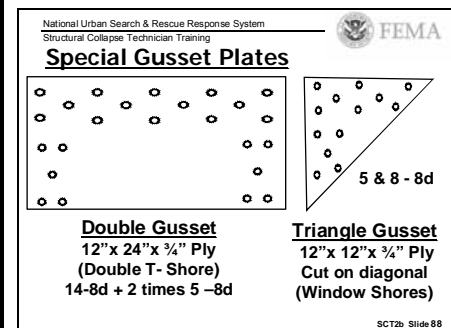
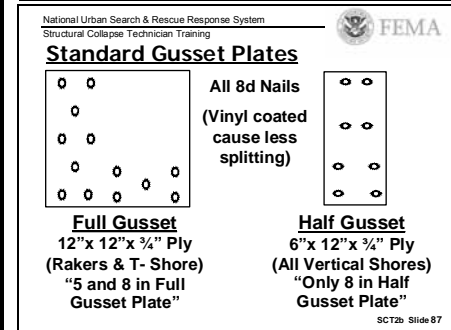
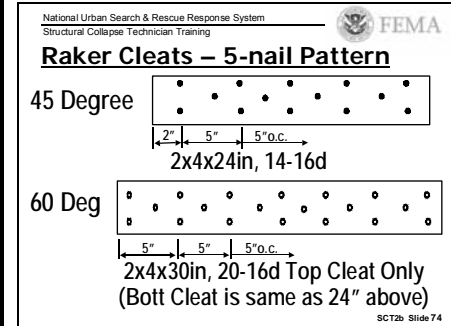
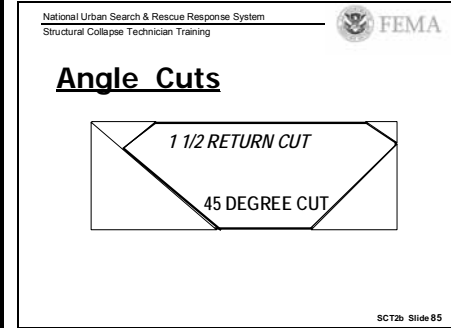
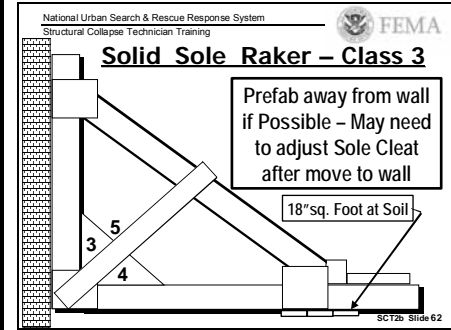



HOW to CONSTRUCT a SOLID SOLE RAKER (cont.)

5. After Anchoring the Sole Plate as noted in 10. on next page, install wedges between the bottom cleat and the base of the Raker and tighten them slightly.
 - a. After adjusting the shims/spacers (if any) between the wall plate and wall being shored to ensure full contact, as in 4a. above, finish tightening the wedges and complete nailing of gusset plates on each side.
 - b. When the sole is being supported by soil, add 3- 2x6x18" under the sole where it intersects raker
6. With Raker shore erected, prevent the Raker shore from sliding up the wall. See Raker Shore - Cleats, Cuts & Anchors.
 - a. To attach wall plate to concrete/masonry wall.
 - A minimum of two 1/2" drill-in anchors, lag screws or rebar should be placed through the wall plate or four 1/2" drill-in anchors through two 9" long channel brackets attached with two on each side of the wall plate near the middle.
 - On concrete walls, if backing material is needed, then attached to wall plate, and use at least five 3" powder charge pins with washers through the backing material on each side of the Raker (also may use 3 - 3/8x4" Concrete Screws each side.)
 - b. To attach the wall plate directly to a wood framed wall. (best attachment may be at floor line)
 - At least two 1/2" lag screws should be placed through wall plate into floor rim joist/blocking.
 - When plywood backing is attached to the wall plate (use 16d@6"o.c.), use at least 8-16d nails through the backing into wall studs, and/or rim joist/blocking, each side of Raker
7. Attach Mid Point Braces (required if 4x4 raker is longer than 11 ft and/or 6x6 raker is longer than 16 ft)
 - a. One 2x6 are nailed to both sides of the Wall Plate/Sole Plate connection and mid-point on the Raker. (if 2x6 is not available, 2x4 may be used)
8. Attach Horizontal Braces
 - a. Connect Raker shores together near the top and bottom of the Raker with at least 2x6 size material, or two 2x4s.
 - b. For Insertion Point greater than 8 feet, a Horizontal Brace shall be placed near mid-point of the Raker, near where Mid-Point Braces intersect

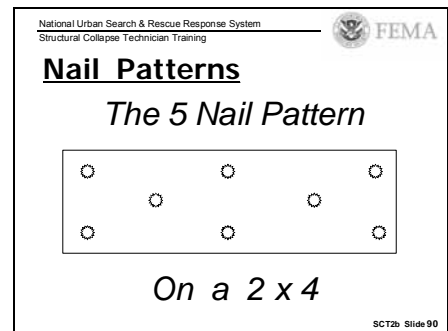
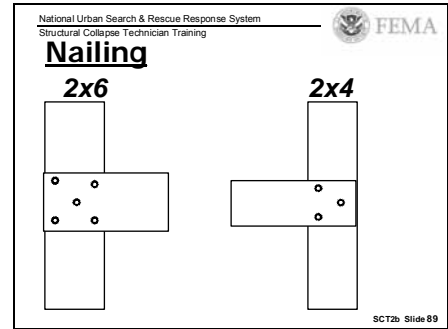



HOW to CONSTRUCT a SOLID SOLE RAKER (cont.)

9. Attach X or V Braces
 - a. All Raker shore systems must be connected with either X or V bracing near the top and bottom of the Raker between at least two Raker shores with 2x4 or 2x6.
 - b. Attach the **first brace to the Rakers** near the top and bottom between the upper and lower horizontal braces.
 - c. Attach the **second brace to the upper and lower horizontal braces** near the Rakers.

10. After the Solid Sole Raker Shore is assembled, prevent the sole plate from sliding back away from the wall.
 - a. To attach the sole plate directly to concrete, asphalt or dirt: drill a minimum of two 1" holes through the sole plate, concrete, or asphalt and drive 1" x 48" steel pickets or rebar directly into the ground. Need at least 4 – 1" x 48" diameter pickets if driven directly into ground, but it may be more practical to use Sole Anchor as in 10 c. below.
 - b. To attach the sole plate to concrete and masonry.
 - A minimum of two 1/2" drill-in anchors, lag screws or rebar should be placed through the sole plate or four 1/2" drill-in anchors through two 9" long channel brackets attached with two on each side of the sole plate.
 - On concrete only, when backing material is attached to the sole plate, the use of at least five 3" powder charge pins with washers through the backing material on each side of the sole plate is acceptable.
 - c. An anchor can be secured to the ground or floor behind the sole plate to prevent the sole plate from backing away from the wall.
 - Timber Anchors should be as least 4x4 size lumber, (6x6 is better). Place 4 – 1" dia x 48" pickets, spaced about 12" o.c., directly behind Anchor on Soil. Use 2 pickets into Paving.
 - Steel anchors or channel brackets should be at least 1/4 inches thick.
 - Concrete curbs, walls and other nearby secure structures may also be used.

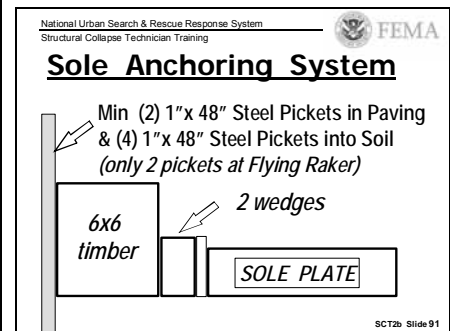



THE RAKER SHORE (continued)

RAKER SHORE

O/H-14-08
11/08

SPLIT SOLE METHOD

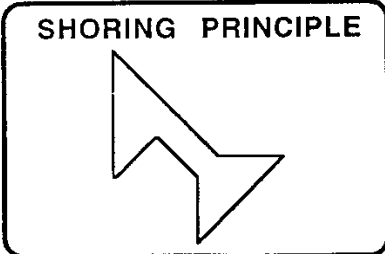
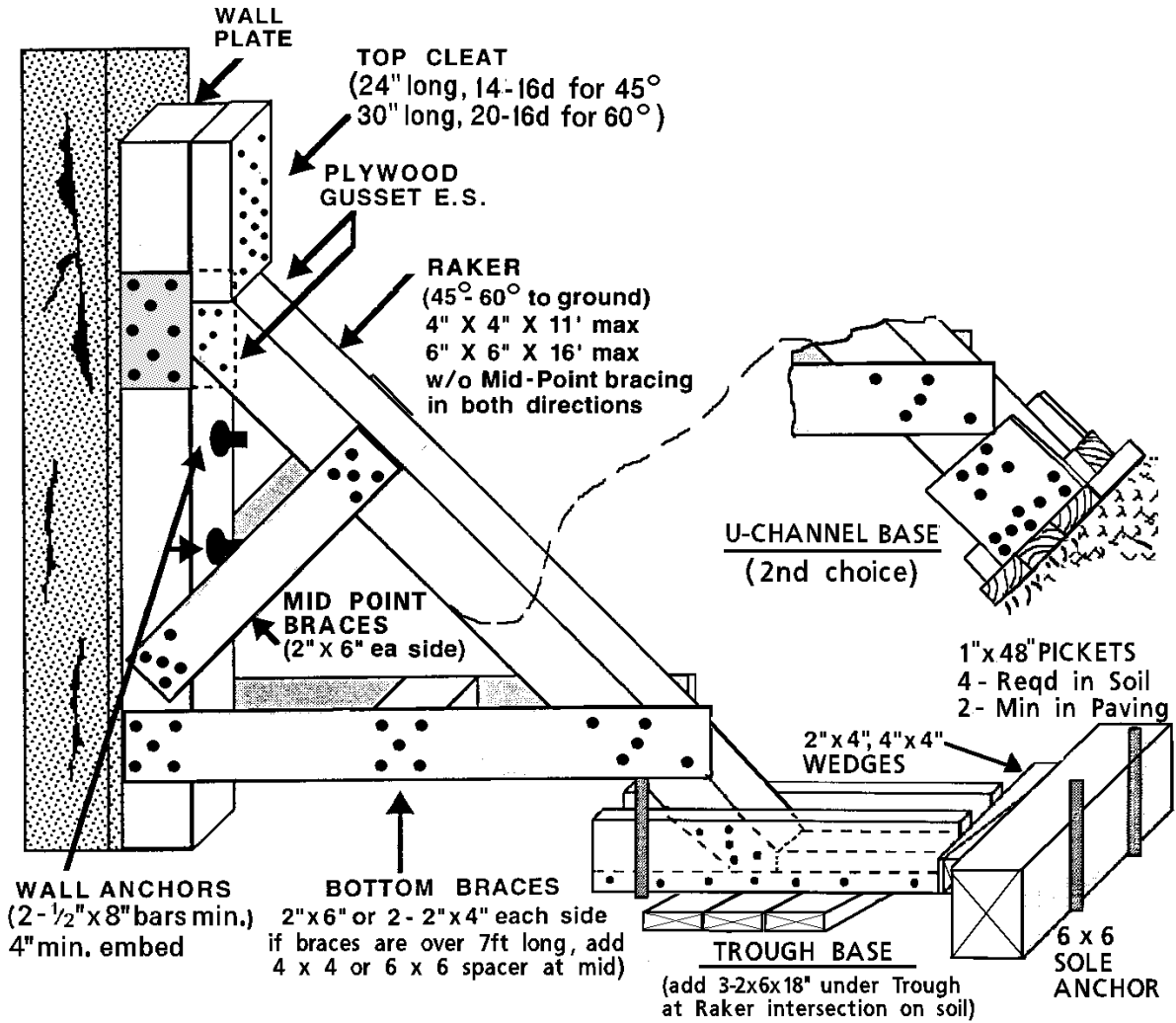

WALL PLATE & RAKER SHOULD BE SAME WIDTH FOR BRACES TO BE MORE EFFECTIVE

NOTE:
U-CHANNEL REQUIRES DIGGING NEAR THE WALL, WHICH MAY BE DANGEROUS
SEE FOLLOWING PAGES FOR DETAILS OF BASES



HOW to CONSTRUCT a SPLIT SOLE RAKER SHORE

- Determine where to erect the Raker Shores and the height of its support points. Determine height of Insertion Point
 - After initial temporary shoring has been installed as needed, clear the area of debris.
 - For each Raker clear three feet wide and at least the height of the support point out from the wall.
- Select angle of Raker, then measure and cut the Wall Plate, Raker, and Bottom Brace to the proper length.
 - If there is rubble next to wall, Wall plate will not extend to the ground, and Bottom Brace should be attached 6" from bottom of Wall Plate, and slope down to Base
 - Raker angle should be 60 deg if U-Channel Base is used, but may be 45 or 60 deg if Trough Base is used
 - If Trough Base is used, both ends of the Raker to be angle-cut with 1½" return cuts for full contact with the wall plate, top cleat, and Trough Cleat
 - For U-Channel Base, one end of Raker will be angle cut.
- In order to pre-fabricate, Cut Raker, Wall Plate and Bottom Brace to proper length, and perform angle cuts on Raker
 - Layout Wall Plate, Raker and Bottom Brace at selected angle, and toenail Raker to Wall Plate.
 - Nail on Top Cleat, then nail gusset to one side of this joint
 - Nail one-Bottom Brace to Wall Plate, 12" from bottom, or in position to clear debris, but only tack-nail it to Raker.
 - Turn Shore over and nail-on other gusset plus other Bottom Brace to Wall Plate
 - Tack-nail Bottom Brace to Raker, so it can be moved into place at the wall.
 - If there is rubble against the wall the Bottom Brace should slope down from the wall to the Raker Base, and intersect as close to the Base as possible

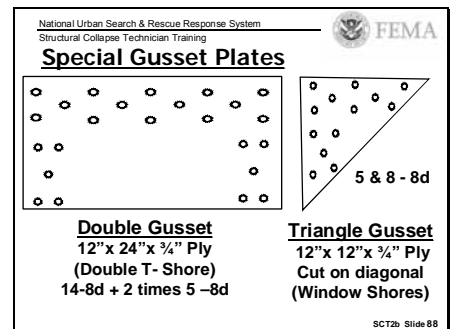
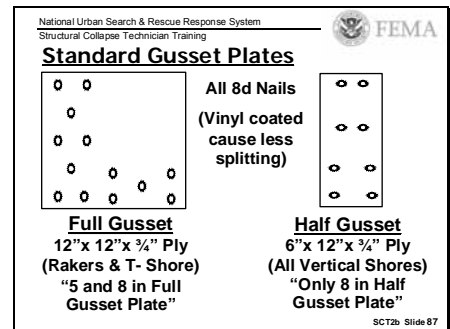
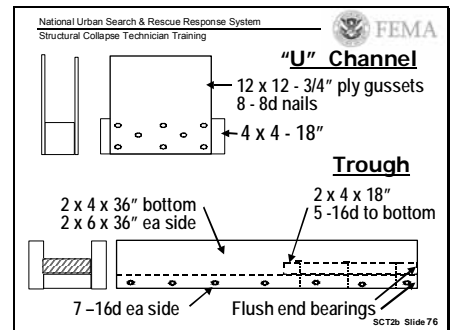
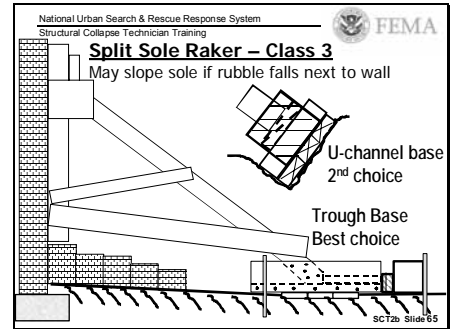



HOW to CONSTRUCT a SPLIT SOLE RAKER (cont.)

4. Carefully move the partially prefabricated Split Sole Raker in place at the wall and make sure it is plumb.
 - a. When a Trough Base is used, after securing the Sole Anchor, drive wedges slightly against the Trough.
 - b. U-Channel Base requires a shallow hole dug at a 30 to 45 degree angle for the Raker bearing
 - Place the wedges on the top of the 4 x 4 x 18" bottom piece of the U-channel and drive them slightly.
 - Not that this base is 2nd choice, since it requires rescuers to work in a danger zone in order to dig-in the base
 - c. When a Trough Base is used, after securing the Sole Anchor, drive wedges slightly against the Trough.
 - d. Full contact must be maintained between the wall plate and the support point of the Raker, and between the base of the wall plate and the wall.
 - If the wall has bulged out, shims may need to be added near bottom of wall plate)
 - e. After adjusting the shims/spacers (if any) between the wall plate and the wall being shored to ensure full contact, finish tightening the wedges and/or complete nailing of the Bottom Brace on each side.
5. With Split Sole Raker shore erected, prevent the Raker shore from sliding up the wall. See Solid Sole Raker Shore
6. Place the Mid-Brace, if required by length of Raker, and erect the Horizontal and X-bracing
7. Anchor the Sole Anchor when Trough is used, same as for Solid Sole Raker Sole Anchor

OTHER PRE-CONSTRUCTED RAKER SHORES

- Pneumatic Shores can be used as temporary Rakers as illustrated in adjacent slide. They would be replaced with properly braced wood system for ongoing operations.

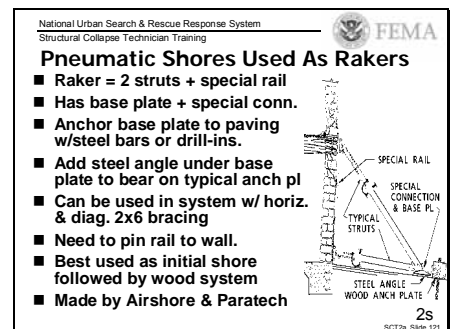
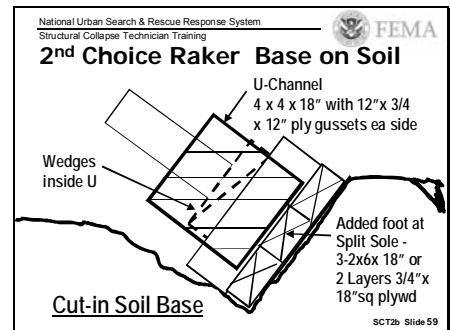
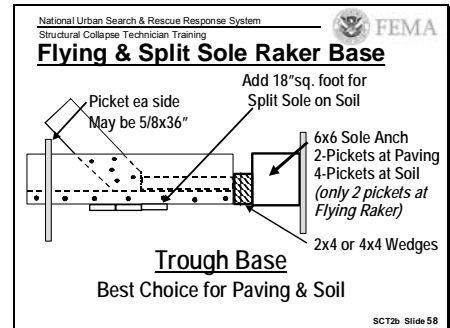



RAKER SHORE CONNECTIONS

RAKER SHORE

O/H-17 09
06/08

CLEATS, CUTS & ANCHORS

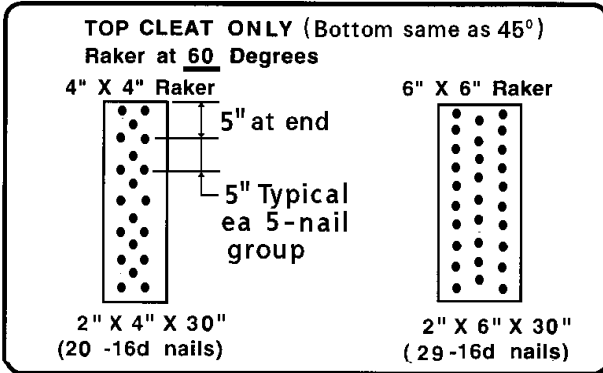
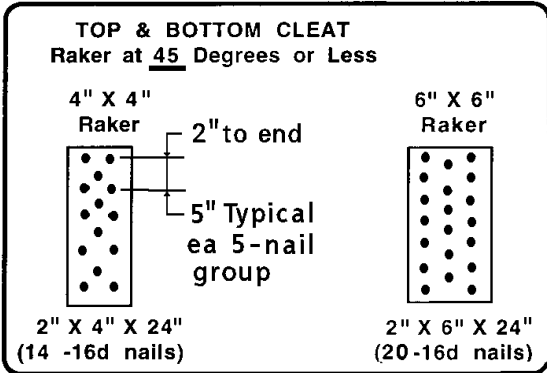

HOW TO CUT THE TOP & BOTTOM ENDS OF THE RAKER

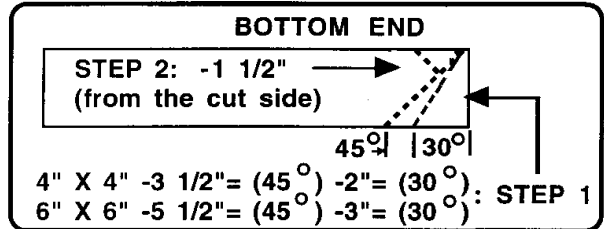
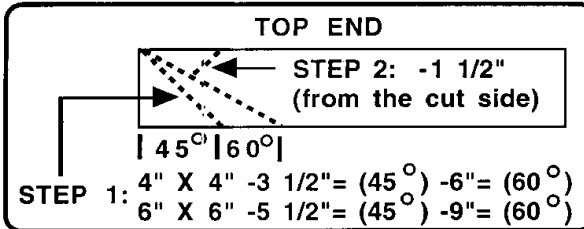

HOW TO ANCHOR THE WALL PLATE & SOLE PLATE OF A RAKER SHORE (Many alternatives are shown - need only one type at Wall and at Sole)

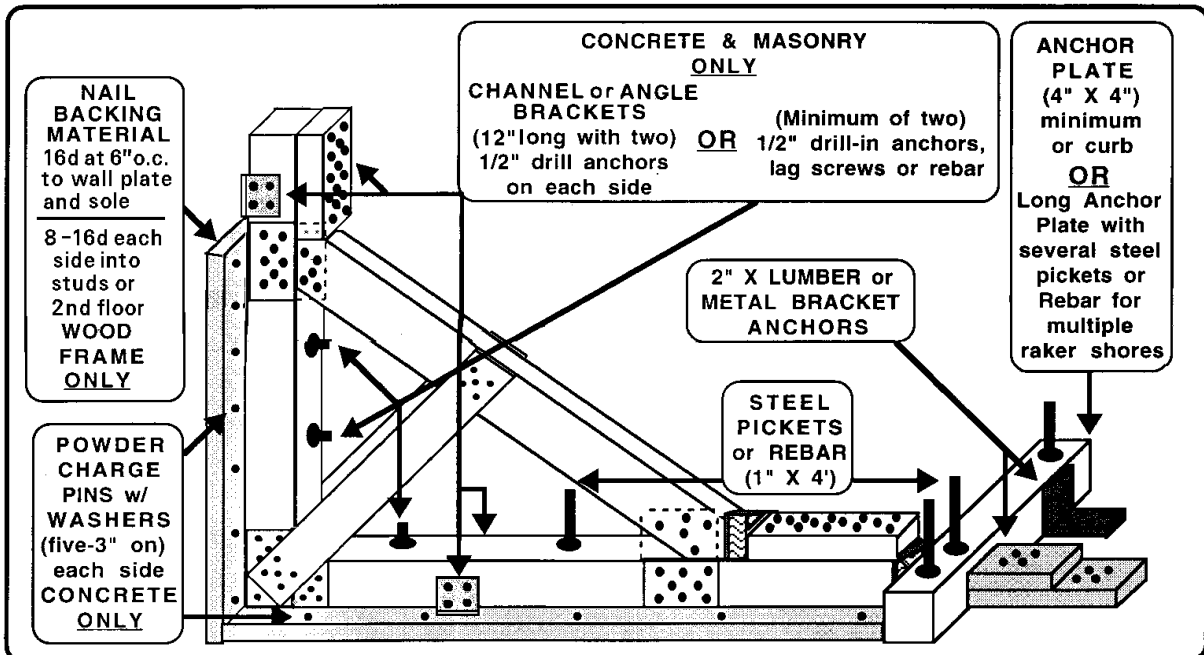



PRE-CONSTRUCTED VERTICAL SHORING SYS

All shoring should be **pre-fabricated** if possible, to **Minimize the exposure of Rescue Personnel to Risk**

The Vertical Shoring Systems to pre-construct are:

- The “T” and Double “T “ Spot Shores
 - Assemble header and post by nailing the upper gussets on both sides.
 - Sole plate, wedges, and half-gussets are added after shore is positioned (as previously discussed)
- Vertical Shore with two posts, diagonal braces and half-gusset plates or cleats connecting the header to the posts.
 - Assemble entire system except for bottom diagonal brace.
 - After moving shore into position, tighten wedges, add bottom diagonal brace, add and nail bottom half-gussets.
- **Ellis Shores** used as a “T” Shore with adjustable post.
 - Ellis Clamp positions on posts are as listed in adjacent slide. (use two nails at each clamp, 8 per post)
 - Slide the upper post under the clamps and manually raise to proper height and pull down on the top clamp.
 - Attach the shore-jack to the lower post under the upper post and lift on the handle.
 - While pressure is being applied to the shore-jack, tap downward on the unsecured end plate of the top clamp and then tap downward on the unsecured end plate of the bottom clamp with a hammer to lock the clamps in place.
 - Assemble header and post by nailing the upper gussets on both sides.
 - Sole plate, wedges, and lower cleats are added after shore is positioned.

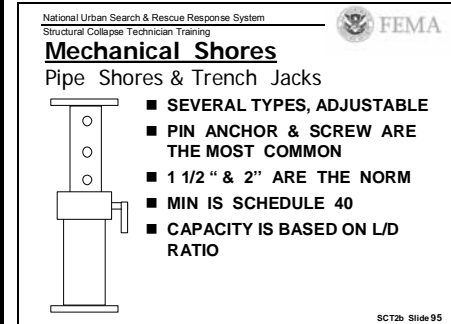
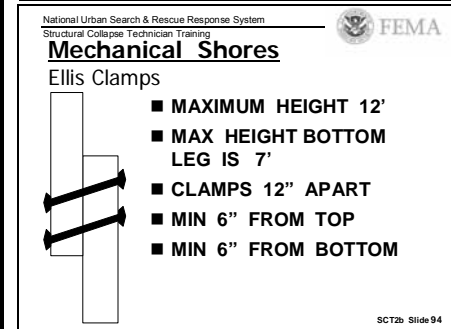
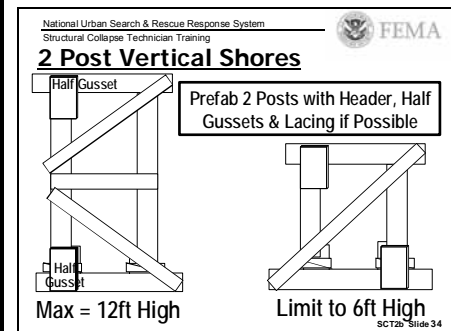
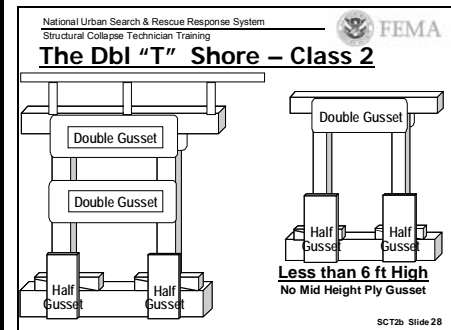
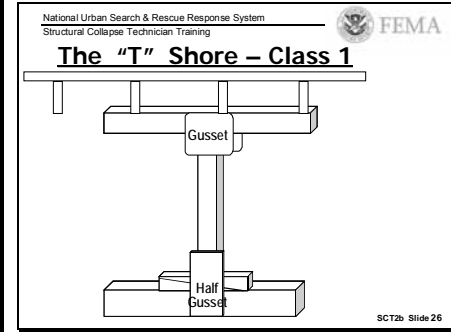



PRE-CONSTRUCTED VERTICAL SHORING SYS (continued)

- **Post Screw Jack**, with one or two posts with gusset plates or cleats connecting the header to the posts.
 - Metal Foot should be nailed to sole.
 - Diagonal braces should be added to multi-post system as for Vertical Shores.
- **Pipe Shores**, with one or more shores.
 - Metal ends should be nailed to header and sole.
 - Diagonal braces cannot be attached unless a special metal fitting is provided by manufacturer.
 - Capacity of 2" pipe is similar to 4x4 wood post, and is dependent on height.
 - Special pipe frames are available that are assembled as a group of four columns with cross bracing, similar to a Laced Post System
- **Pneumatic Shores**, with one or more shores with wood or metal rail header.
 - Metal ends should be nailed to header and sole
 - One manufacturer sells a clamp fitting that allows for, nailed 2x 6 "X" bracing to be installed.
 - Pneumatic shores are best used as temporary shores.
 - Some manufacturers provide a Header Rail that may be pre-assembled with two or more struts to provide a pre-constructed, vertical shore.
 - **WARNING** – The use of Air Pressure to raise these shores into place has caused Accidents. Air Pressure should be limited to 50 PSI, and **All Pneumatic Struts should be Hand Tightened**
- **Window/Door Shores** may be pre-constructed as shown in adjacent slide
 - They should be made at least 1 ½" less than opening in each direction, and then tightened with wedges at one side and on bottom.
 - If header is badly damaged, great care may be taken while inserting the shore and the shims
 - They may not be practical in racked or otherwise deformed openings.
 - For large openings, they may be too heavy to carry up to locations above ground floor.
 - Their main advantage is allowing pre-construction away from the dangerous wall or collapse zone.

National Urban Search & Rescue Response System
Structural Collapse Technician Training



Screw Jack by Ellis

- Adjustable metal foot for 4x4 and 6x6 wood posts
- 6 inch adjustment - set half way to get 3 in. up & down
- Metal Foot is stronger than wood post
 - Use sole to spread load



SCT2b Slide 42

National Urban Search & Rescue Response System
Structural Collapse Technician Training



Mechanical Shores

Pipe Shores & Trench Jacks

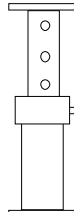

- SEVERAL TYPES, ADJUSTABLE
- PIN ANCHOR & SCREW ARE THE MOST COMMON
- 1 1/2" & 2" ARE THE NORM
- MIN IS SCHEDULE 40
- CAPACITY IS BASED ON L/D RATIO

SCT2b Slide 95

National Urban Search & Rescue Response System
Structural Collapse Technician Training



Pneumatic Shores

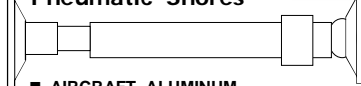

- AIRCRAFT ALUMINUM
- 18" EXTENDING TO 16'
- MAY USE UP TO 50PSI AIR TO RAISE THESE STRUTS IN STRUCTURAL COLLAPSE
 - BUT HAND TIGHTENED, SNUG TIGHT
- WORKING LOAD VARIES
 - DEPENDING ON LENGTH

SCT2b Slide 96

National Urban Search & Rescue Response System
Structural Collapse Technician Training



The Window Shore

Pre-constructed Method
Build frame with plywood gussets at each corner, 1 ½" less than opening each way.
Insert in opening, then add Wedges at side and bottom.

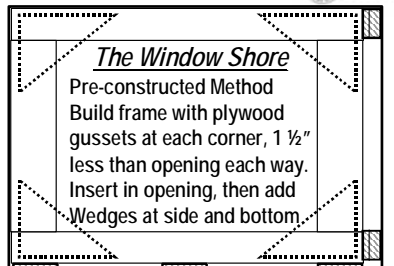

SCT2b Slide 50



MEASURING NOTES

The following explain how to measure shoring materials while deducting for wedges, the proper use of wedges and maximum thickness while maintaining full contact with perpendicular shoring materials.

- When possible, round off shoring material measurements to the nearest $\frac{1}{2}$ inch to ease in marking and cutting.
- When using 4 x 4 x 18" wedges deduct the thickness of one wedge from the length of the shoring material being measured.
- When using 2 x 4 x 12" wedges deduct the thickness of one wedge from the length of the shoring material being measured.
- 4 x 4 x 18" wedges can be moved together to a thickness of 6" while still maintaining full contact with a perpendicular 4 x 4.
- 2 x 4 x 12" wedges can move together to a thickness of 2 $\frac{1}{4}$ " while still maintaining full contact with a perpendicular 4 x 4.

SUPPLIES AND EQUIPMENT

The use of the same dimension lumber for the headers, wall plates, sole plates, posts and struts will ease in the construction of the shoring systems and make the braces more effective.

(The use of Duplex 16d and 8d nails in Training, will assist in the dismantling of the shoring systems and reduce the amount of destroyed shoring materials during the dismantling process.)

- Cleats should be 2 x 4 x 14" min (18" for less splitting)
- Plywood gusset plates should be 12" X 12" X $\frac{3}{4}$ " thick.
- Pairs of 18" square x $\frac{3}{4}$ " Ground Pads are used under the U-channel for Raker and Sloped Floor Shores bearing on soil.
- Smaller gusset plates can easily be formed by cutting the larger square gusset plates in half, making four 6" x 12" gusset plates.
- Triangle gusset plates (12" x 12" x 17") can be easily formed by cutting a 12"x 12" full-gusset plates in half from one corner to the opposite diagonal corner.



USING the STEEL FRAMING SQUARE for RAKER SHORES

- **The Tongue:**
 - Shorter, part is usually 16" long and 1 ½" wide.
- **The Body (blade):**
 - Usually 24" long and 2" wide.
- **The Heel:**
 - The point where the tongue and the body meet on the outside edge.
- **The Face:**
 - The side with the manufacturer's stamp.
 - The side that is visible when the body is held in the left hand and the tongue in the right hand.
- **The Back:**
 - Opposite of the face.

THE SCALES AND TABLES

- There are seven different scales and tables on the steel framing square:
 - Four of the seven scales and tables may be used for rescue shoring.
- **The Rafter Table:**
 - Found on the face of the square, on the body.
 - Used to determine the lengths of common, hip, valley and jack rafters and the angles at which they must be cut to properly fit ridge board/top plates for roof framing.
 - Can be used to determine the length of the raker,
 - However, one must remember that Rafter Table is based on the Run (horizontal distance).
 - Rakers are based on the Insertion Point (vertical distance up the wall)
- **The Brace Table:**
 - Found along the center of the back of the tongue, giving lengths from 24" to 60" forming 45° angles.
 - Determine length of short rakers/corner bracing.
- **The Hundredths Scale:**
 - Found on the back of the tongue, near the heel.
 - Consists of 1" divided into one hundred parts.
 - Useful to convert lengths given in hundredths.
- **The Inch Scale:**
 - Found on both the body and the tongue along the inside and outside edges of the square.
 - For measuring inches and graduations of an inch.



USING FRAMING SQUARE for RAKER SHORES

- The Steel Framing Square may be used to Scribe the Cut Angles for Rakers (**Figure: 1 on O/H - 18**)
 - Place the square on the raker with heel pointing up and body on the left side and tongue on the right. (It may be body at right and tongue at left)
 - **For a 45 deg** raker, position it so that the number 12" on the body and tongue are aligned at what will become the top of the raker (actually any pair of equal numbers from 6 to 12 may be used, 6 "– 6", 7" – 7", etc)
 - Scribe a line on the slope at the Right
 - Slide the Framing Square to the far end of the raker the required distance (See Raker Dimension Table, Pg 34 or use one of the methods given below)
 - Then realign the 12" – 12" to the edge of the raker and Scribe a line at the Left
 - Finally make a 1½" perpendicular cut
 - **For a 60 deg** raker, position it so that the number 12" on the body and 7" tongue are aligned at what will become the top of the raker
 - Scribe a line on the slope at the Right. This will become the Wall End of the rake
 - Slide the Framing Square to the far end of the raker the required distance
 - Realign the 12" – 7" to the edge of the raker & scribe line at left. Make 1½" perpendicular. cut
- There are Two Methods to determine the length of a raker using the Steel Framing Square
 - The Diagonal Method
 - The Step-Off Method
- The Diagonal Method (**Figure: 2 on O/H - 18**)
 - The least accurate of the two methods.
 - Use the tongue to simulate the wall and the body to simulate the floor.
 - Use the inch markings on the outside edges as "foot measurements".
 - Place the tape measure tip on the outside inch mark simulating the support point on wall and lay it across the square until it intersects the outside inch mark on body simulating support contact pt.
 - The length of the tape measure when it is intersecting the outside tongue and body inch marks will be the length of the raker from tip to tip.
 - Example: 9 ft high support point on the wall, 9 ft back from the wall will be a 12'-9" long raker.



USING FRAMING SQUARE for RAKER SHORES

- The Step-Off Method (**Figure: 3 on O/H - 18**)
 - **Note it is much easier and more accurate to use the Raker Dimension Table**
 - Place the square on the raker with heel pointing up and the body on the left side and the tongue on the right.
 - Use the tongue to simulate the wall and the body to simulate the floor.
 - Use the inch markings on the outside edges as “foot measurements”
 - Align the tongue outside edge inch mark representing the height **in feet** of the support point on the wall with the bottom edge of the raker.
 - Align the outside edge inch mark on the body representing the length in feet away from the wall the contact point on the floor with the bottom edge of the raker.
 - Scribe a line, which will be the top cut of the raker along the outer edge of the tongue.
 - Mark the point where the outer edge inch mark of the body contacts the bottom edge of the raker.
 - Hold the square with the outer edge inch marks remaining constant and “step” over the pencil mark to the left and place outer edge inch mark of the tongue next to it.
 - Realign the same outer edge inch marks as before and mark the point where the outer edge inch mark of the body contacts the bottom edge of the raker.
 - Repeat this “step” as many times as there are feet in the length away from the wall.
 - On the last “step” scribe a line along the outer edge of body for the bottom cut of the raker.
 - Example: 9 ft high support point on the wall, 9 ft back from the wall will be a 12’-9” long raker.
 - 9” mark on the outer edge of the tongue and the 9” mark on the outer edge of the body is “stepped” over these marks twelve times.
 - Measuring the distance covered after twelve steps is 12’-9” ft tip to tip.



USING THE STEEL FRAMING SQUARE

O/H-18

Figure:1 TO SCRIBE THE CUT ANGLE ON A RAKE

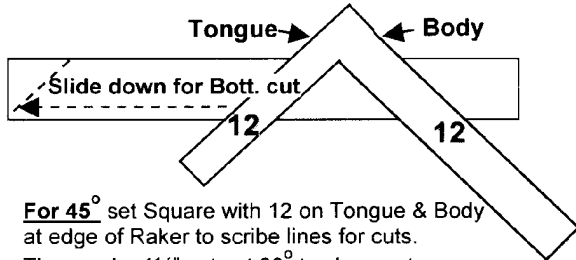

For 45° set Square with 12 on Tongue & Body at edge of Raker to scribe lines for cuts. Then make 1½" cuts at 90° to slope cuts

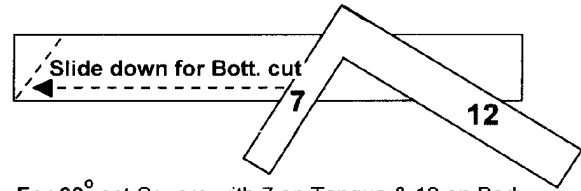
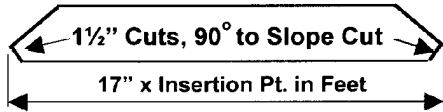

For 60° set Square with 7 on Tongue & 12 on Body at edge of Raker to scribe lines for cuts. Then make 1½" cuts at 90° to slope cuts

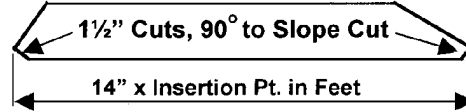

Figure:2 TO DETERMINE THE APPROXIMATE LENGTH OF A RAKE

The Diagonal Method

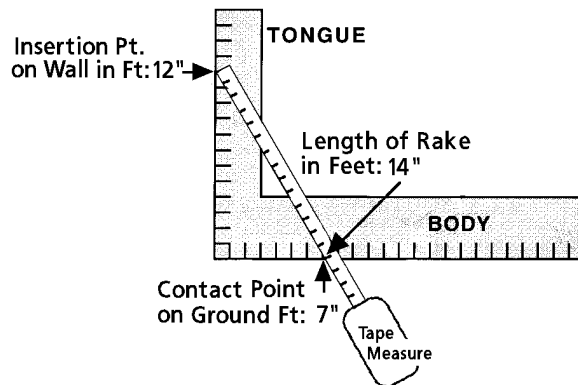
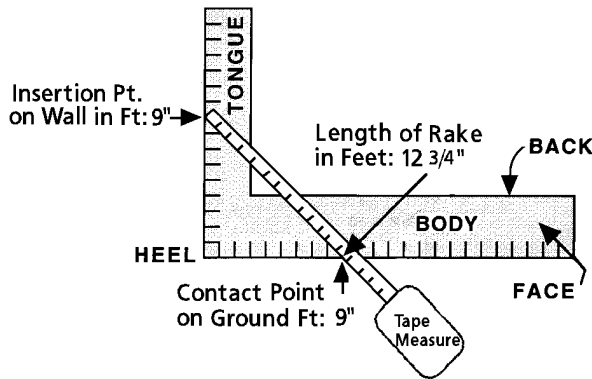
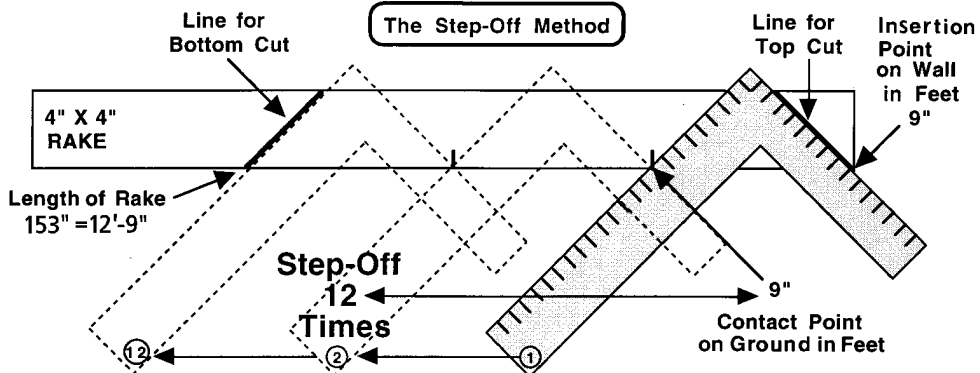

Figure:3 TO DETERMINE THE APPROXIMATE LENGTH OF A RAKE

The Step-Off Method





EQUIPMENT AND CUTTING STATION (continued)

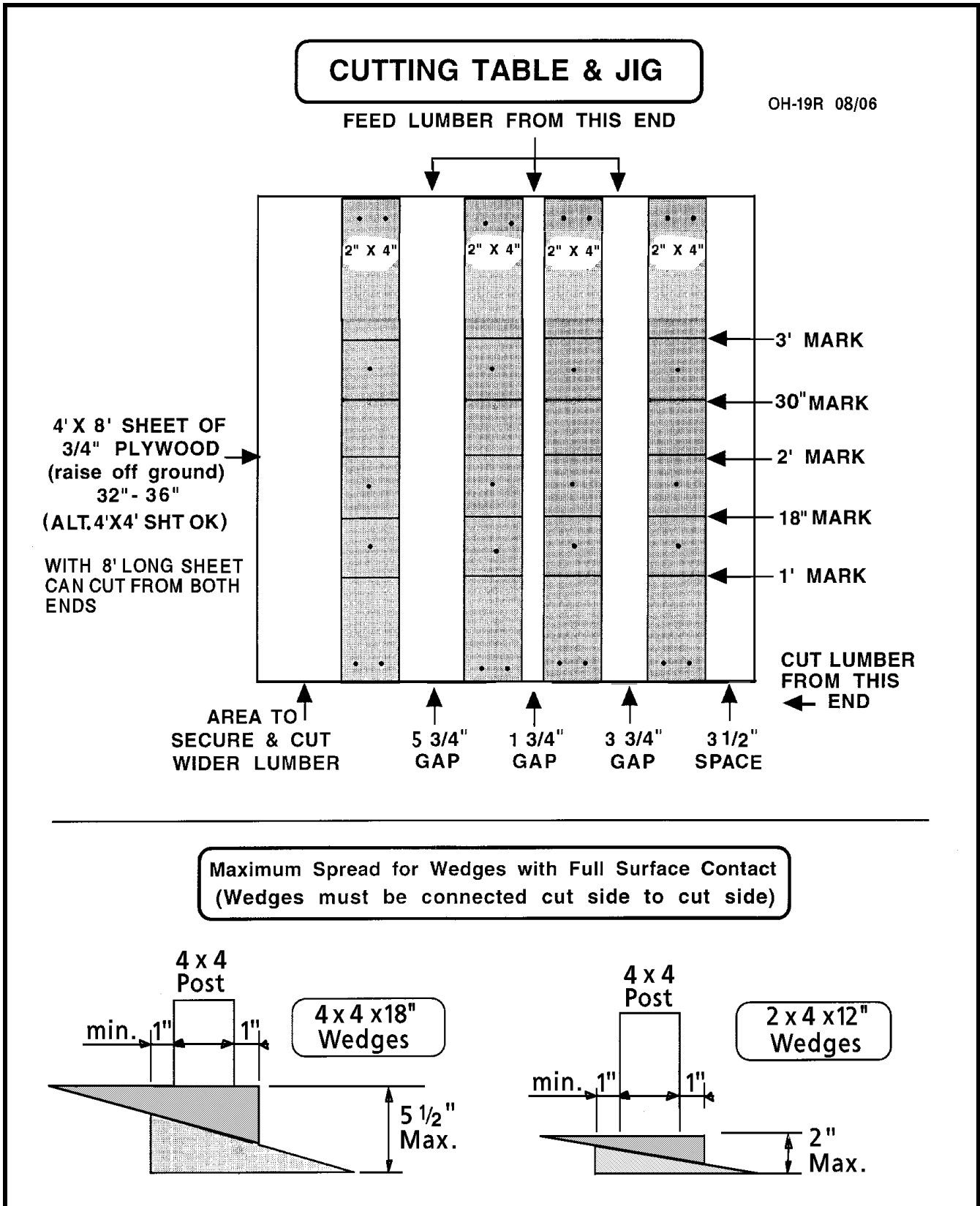



HOW TO CUT WEDGES

- Cutting 4 x 4 x 18" wedges.
 - Mark a full length 4 x 4 x 8 ft every 18".
 - This will make five pair of wedges with a 6" piece left to secure the last pair while being cut.
 - Mark a diagonal line from the top edge of one 18" line to the bottom edge of the opposite 18" line every 18 inches.
- Cutting Wedges with a Rotary Saw
 - Score the line with the blade 1/2" deep.
 - Second pass cut half way through.
 - Third pass cut all the way through.
 - Cut the other half of the wedge off of the remaining 4 x 4 at the 18" line.
- Cutting Wedges with a Chain Saw
 - Align the blade with the diagonal line on the 4 x 4 with the tip of the saw pointing towards the cutting table.
 - Start cutting with the tip of the saw bar approximately 2" past the edge of the 4 x 4.
 - Once the tip of the saw bar is through the full thickness of the 4 x 4 start to drag the saw towards the opposite end of the diagonal line.
 - Once the heel of the saw is past the end of the 4 x 4, flatten the saw and cut the remaining part of the 4 x 4 with the full bar.
 - Cut the other half of the wedge off of the remaining
- Cutting Wedges with a Circular Saw
 - Difficult to do unless the saw has at least a 10 1/4" blade.
 - Circular saws with blades 10 1/4" or larger need only one pass from corner to corner along the diagonal line.
 - Circular saw with blades less than 10 1/4" require marking and cutting on both sides and do not always align correctly.



HOW TO CUT THE TOP END OF THE RAKE AT 45 & 60 DEG

- Mark the end of the rake to be cut
- 4 X 4 = 3 ½" from the end for 45 degrees
- 4 X 4 = 6" from the end for 60 degrees
- 6 X 6 = 5 ½" from the end for 45 degrees
- 6 X 6 = 9" from the end for 60 degrees
- Mark a diagonal line from the upper end of the lumber to the mark on the lower edge of the lumber and cut the end off at this angle.
- Measure 1 ½" wide on the tapered end and mark a line on the cut side for the relief cut to make full contact with the end of a cleat.
- Cut this line from the cut side with a circular saw.

- The cutting team will mark and cut the end of a rake at 45 degrees and after cutting the angle end cut off the rake, they will cut the end of the rake at 60 degrees.

HOW TO CUT THE BOTTOM END OF THE RAKE AT 45 & 60 DEGREES.

- Mark the end of the rake to be cut
- 4 X 4 = 3 ½" from the end for 45 degrees
- 4 X 4 = 2" from the end for 30 degrees
- 6 X 6 = 5 ½" from the end for 45 degrees
- 6 X 6 = 3" from the end for 30 degree
- Mark a diagonal line from the upper end of the lumber to the mark on the lower edge of the lumber and cut the end off at this angle.
- Measure 1 ½" wide on the tapered end and mark a line on the cut side for the relief cut to make full contact with the end of a cleat.
- Cut this line from the cut side with a circular saw.

- The cutting team will mark and cut the end of a rake at 45 degrees and after cutting the angle end cut off the rake, they will cut the end of the rake at 60 degrees.



HOW TO NOTCH LUMBER FOR ADDED STABILITY

■ How to notch Cribbing (Not Recommended)

- Mark 4" from the end of the cribbing to prevent the end piece from splitting off.
- From the 4" mark, make a second mark the true thickness of the lumber being used for cribbing.
- 4 X 4 = 3 ½" - 6 X 6 = 5 ½"
- Adjust a circular saw to the depth of ½" and cut the two lines and then between the two lines every ½" to 1 inch.
- Ensure saw is unplugged while adjusting blade depth.
- Hit the sliced pieces of lumber with a hammer towards the remaining cribbing to break off the pieces.
- Clean out the notch with the claw end of the hammer until smooth.
- Have one of the squad members repeat this process on the opposite end of the cribbing.
- Notches should only be made on each side of the cribbing to provide full interlock of each piece in each direction.

SUMMARY

We have discussed how to size-up and what considerations that need to be made in order to select the appropriate type, size and location of Emergency Shoring

In addition we have discussed the different types of FEMA Shores, and given step-by-step procedures of how to build each type.

The Structures Specialists FOG from the US Army Corps of Engineers and the Shoring Operations Guide (SOG) both have diagrams and instructions for constructing these shores.

Both guides are available in electronic form on the web site of the FEMA Structures Sub-group.
www.DisasterEngineer.org



Enabling Objectives Summary

- Have a basic understanding of how to conduct a proper shoring size-up
- Be able to identify locations for proper shoring placement
- Understand the shoring team concept and identify positions & purpose
- Understand the different types of shoring components and equipment